



宁波九隆五金有限公司
NINGBO JIULONG HARDWARE CO.LTD



BE WITH US, BE WITH SAFETY!

Office ADD: Room 506-509 No.1357YINXIAN street, Ningbo, China.

Factory Add: No. B-8 Technology park, Ningbo, China.

TEL: 0086-574-82815295

FAX: 0086-574-82815296

Mobile: 0086-13989392999

P.C: 315100

EMAIL: SALES@JLHARDWARE.COM

Website: WWW.NB-JIULONG.COM

WWW.NB-JIULONG.CN

WWW.JLHARDWARE.COM

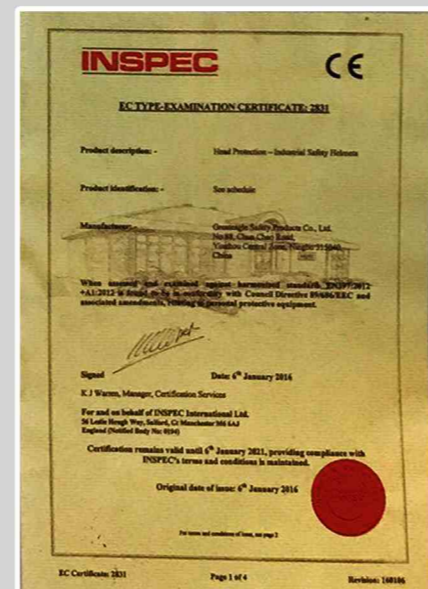
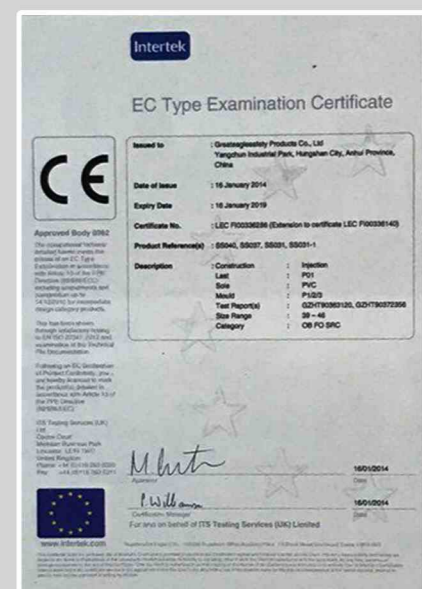
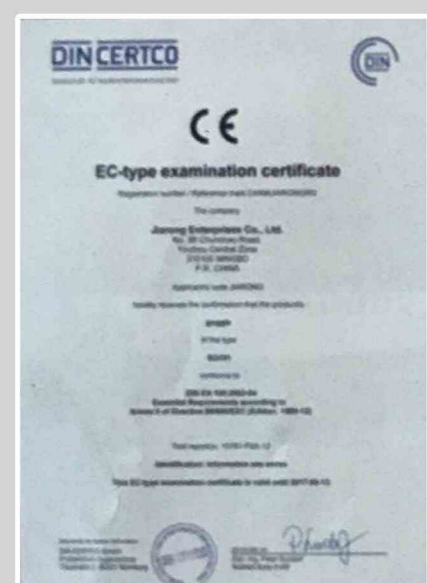

**BROCHURE FOR
TRUCK AND TRAILER PARTS
2023**

contents

body fixings - 1A

door retainers - 1B

T I R cable - 1C

curtain products - 1D

number plate holders - 1E

cargo control - 1F

locks & hinges - 1G

body components



JIULONG HARDWARE

BODY FIXINGS

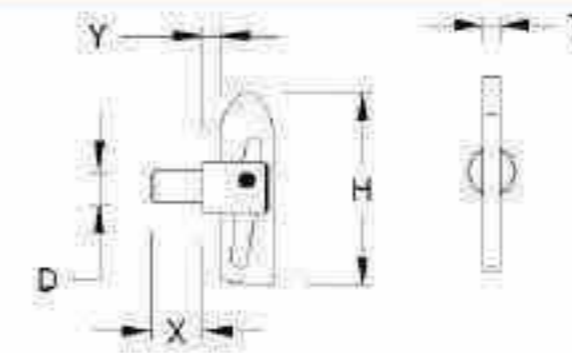

Weld-On Stayfast Latch

- Manufactured in high grade machine steel
- Available in two sizes
- Finish: BZP

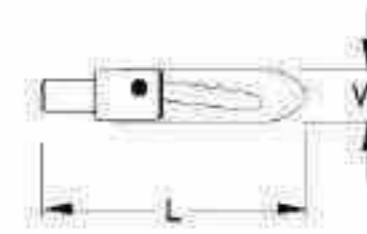

PART NUMBER	L	W	H	T	D	Hs	X	Y	KGS
236010	66.5	13.5	50	4	9	-	9.5	6.8	0.03
236011	91.5	19.5	72	6	12	-	12.5	6.8	0.09

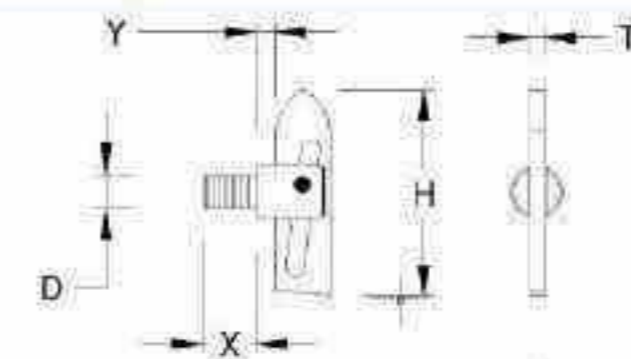

Bolt-On Stayfast Latch

- Manufactured in high grade machine steel
- Supplied in various sizes
- Finish: BZP

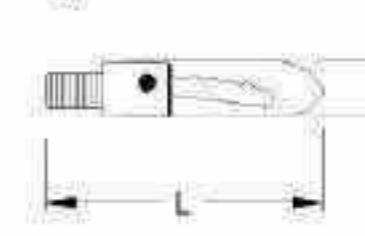

PART NUMBER	L	W	H	T	D	X	Y	KGS
236012	77	12.5	50	4	M8 x 1.25	20	6.8	0.03
236013	95	12.5	50	4	M8 x 1.25	38	6.8	0.04
236014	104	19.5	72	6	M12 x 1.75	25	6.8	0.09
236015	114	19.5	72	6	M12 x 1.75	34	6.8	0.10
236016	155	19.5	72	6	M12 x 1.75	76	6.8	0.12

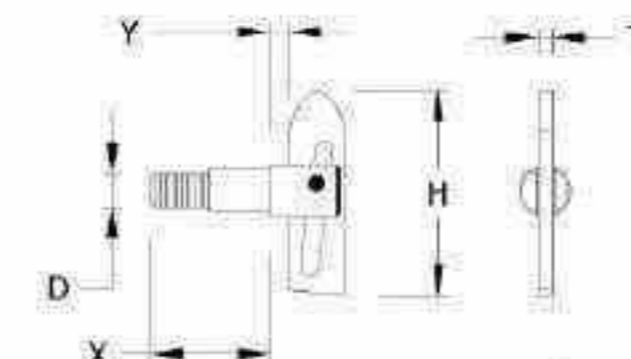

Brewery Stayfast Latch

- Manufactured in high grade steel
- Supplied with cup-washer, spring retaining washer and nylon nut
- Finish: ZYP

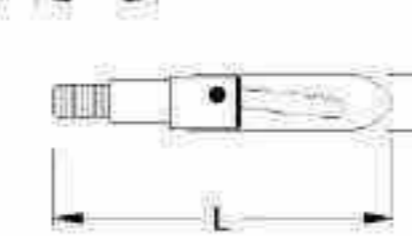

PART NUMBER	L	W	H	T	D	Hs	X	Y	KGS
236017	128	19.5	72	6	12	-	50	6.8	0.19



JIULONG HARDWARE

Tel: 86-574-82815295/82815299

Web: jilhardware.com

Fax: 86-574-82815296

E-mail: sales@jilhardware.com

1A-I

Spring Loaded Sword Pin

- Supplied with 9 link zinc plated chain and tab washer
- Finish: BZP

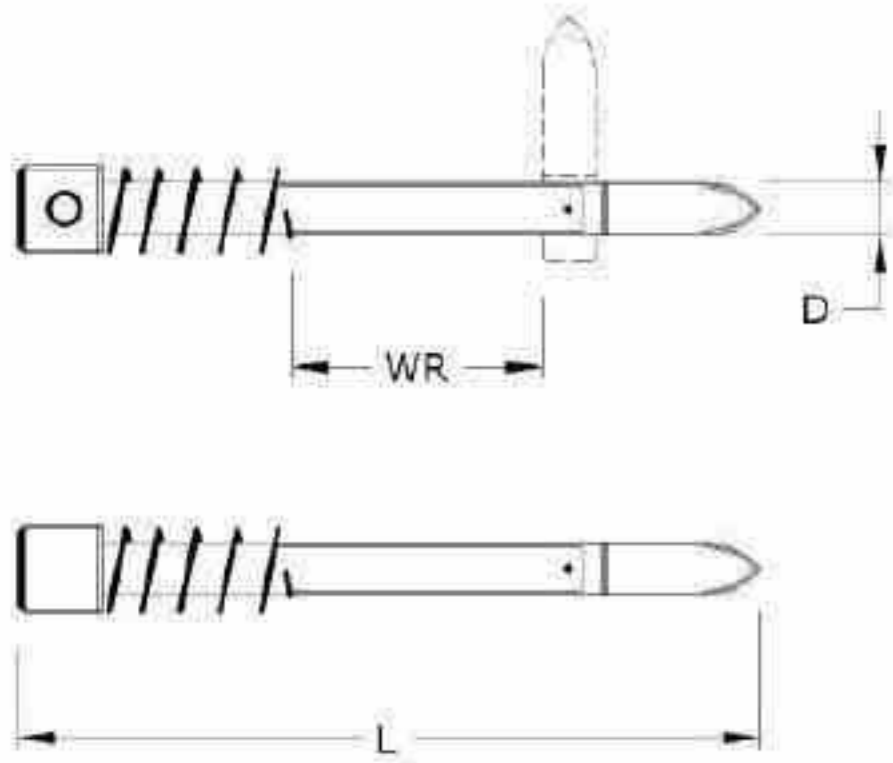

PART NUMBER	L	W	H	D	WORKING RANGE	KGS
236034	112	-	-	10	25 - 35 mm	0.200
236005	122	-	-	10	35 - 50 mm	0.215
236004	148	-	-	12	45 - 65 mm	0.220
236006	176	-	-	16	55 - 76 mm	0.34

Shoot Bolt

- Manufactured in mild steel
- Supplied with plastic end cap
- Three sizes are available
- Finish: BZP

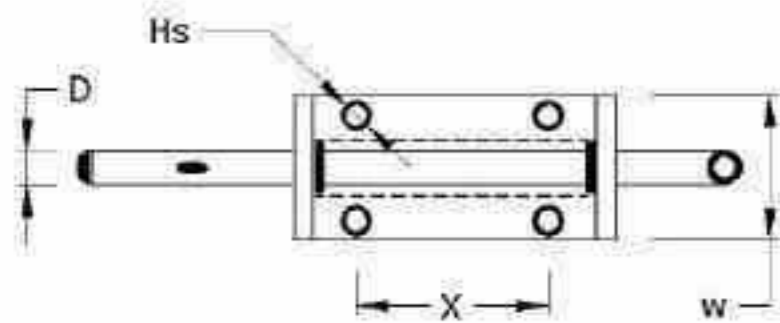
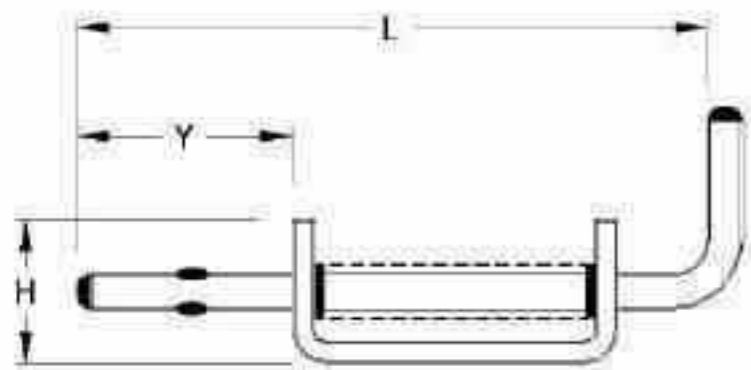

PART NUMBER	L	W	H	T	D	Hs	X	Y	KGS
236001	123	38	23	4	10	6.5	42	35	0.08
236000	150	40	88	4	12	6.5	45	38	0.09
236002	235	52	46	5	16	8	94	50	0.10

'D' Shaped Cotter Pin

- Cold forged with spring clip
- Supplied with or without chain
- Finish: BZP

236003: Without chain
236009: With chain (chain length 290mm)

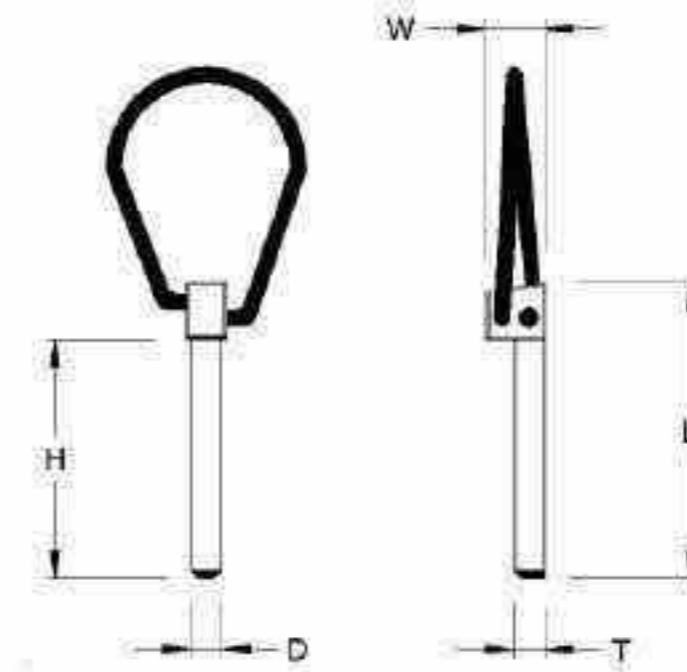

PART NUMBER	L	W	H	T	D	Hs	X	Y	KGS
236003	57.5	14	42	9.5	11	-	-	-	0.04
236009	57.5	14	42	9.5	11	-	-	-	0.08

Round Cotter Pin

- Supplied complete with ring and 9 link chain
- Finish: Pin - EPE; Chain - BZP

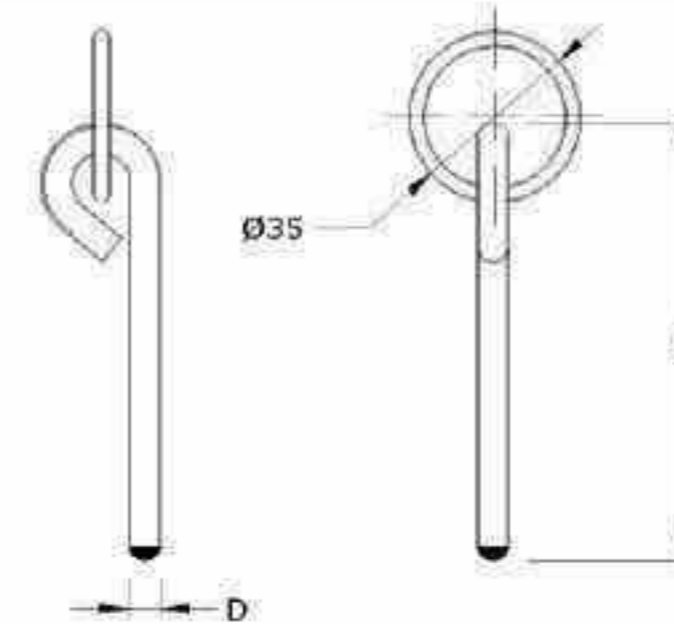

PART NUMBER	L	W	H	T	D	Hs	X	Y	KGS
236007	108	-	-	-	8	-	-	-	0.14

'D' Shaped Flat Cotter Pin

- Manufactured in mild steel
- Supplied with welded ring and 9 link chain
- Finish: Self Colour

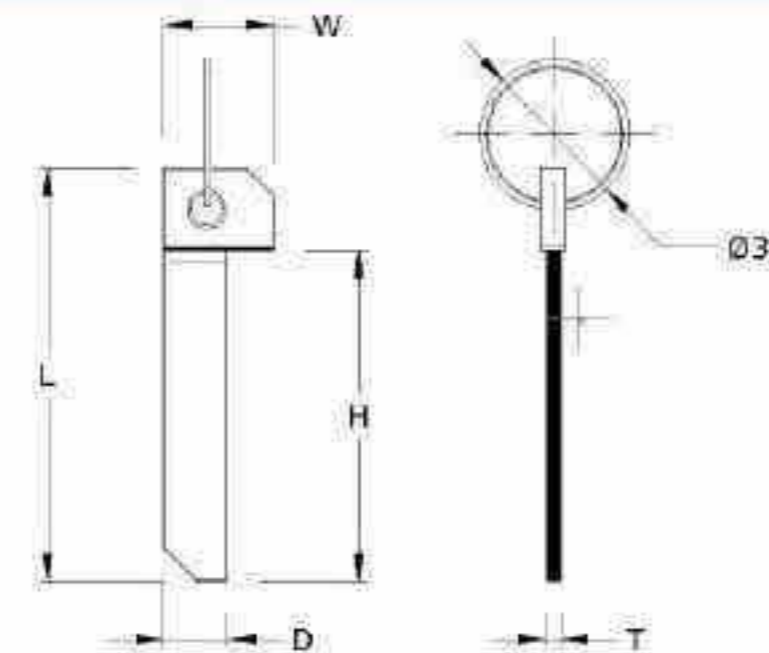

PART NUMBER	L	W	H	T	D	Hs	X	Y	KGS
236008	90	25.5	67	4	14.3	-	-	-	0.12

Spring Hook To Crue

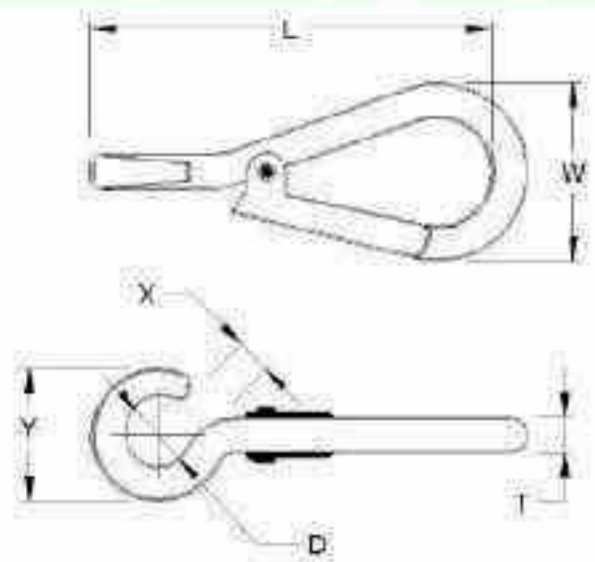

- Steel formed hooks
- Sprung safety catch
- Supplied loose or in boxed quantities
- Finish: BZP



PART NUMBER	L	W	H	T	D	Hs	X	Y	KGS
239003	50	25	-	6	9	-	4	20	0.025
239004	63	32	-	7	10	-	5	23	0.040
239005	75	36	-	8	12	-	6	26	0.075
239006	88	40	-	9.5	14	-	7	30	0.095
239007	102	45	-	10	16	-	8	34	0.120

Spring Hook with Chain

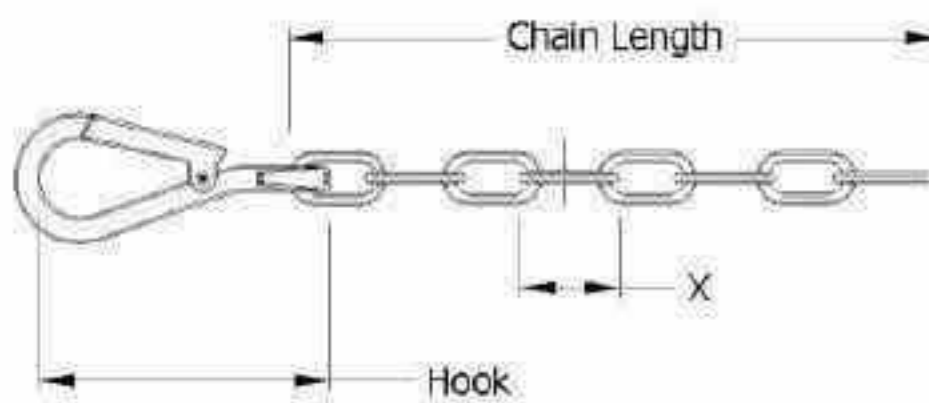

- Hook assemblies supplied with welded chain
- Various end fixings available (ask for details)
- Typical chain construction is 3x21mm
- With a mass of 0.165 kgs/mtr
- Finish: BZP



PART NUMBER	HOOK SIZE mm	CHAIN LINKS	CHAIN LENGTH mm	X	KGS
239008	63	9	180	21	0.029
239009	75	9	180	21	0.044
239010	75	14	285	21	0.090
239011	88	14	285	21	0.124
239012	102	14	285	21	0.126

Mild Steel Welded Chain

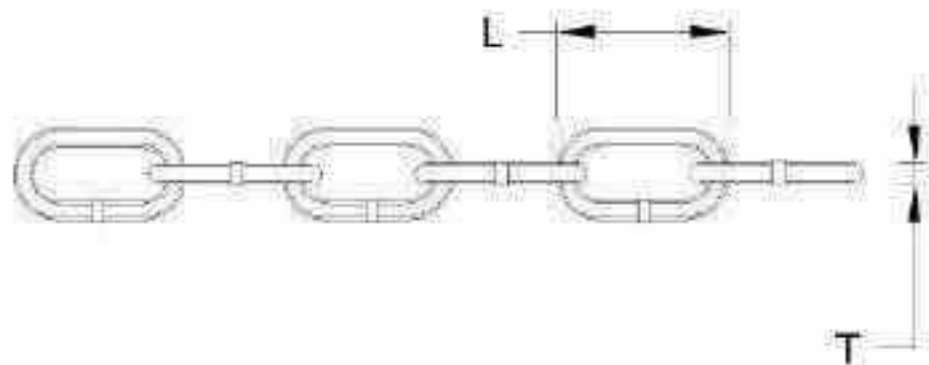

- Supplied in metres
- Test loaded
- Uncertified
- Finish: BZP



Larger hooks have 2 links substituted with a consumer hook

PART NUMBER	L	W	H	T	D	Hs	X	Y	KGS
239019	-	-	-	-	-	-	-	-	0.04

Quick Link

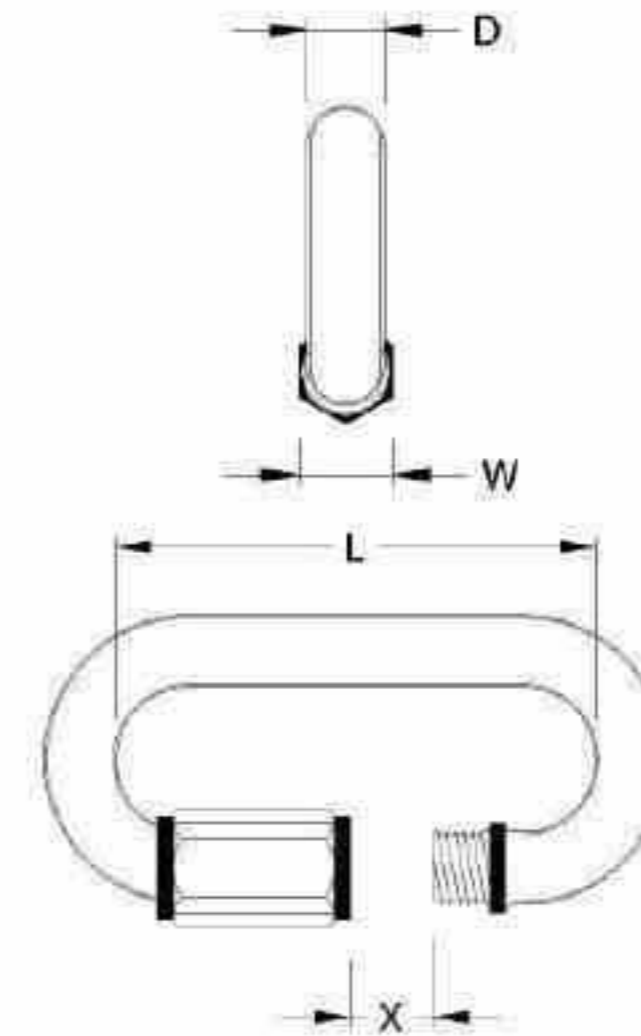

- Manufactured in tensile steel
- Also available in pair and delta options
- Finish: BZP



PART NUMBER	L	W	H	T	D	Hs	X	Y	KGS
239013	70	15	-	-	10	-	12	-	0.125
239014	83	17	-	-	12	-	15	-	0.214
239015	108	19	-	-	16	-	19	-	0.320

Ramp Fastener Set

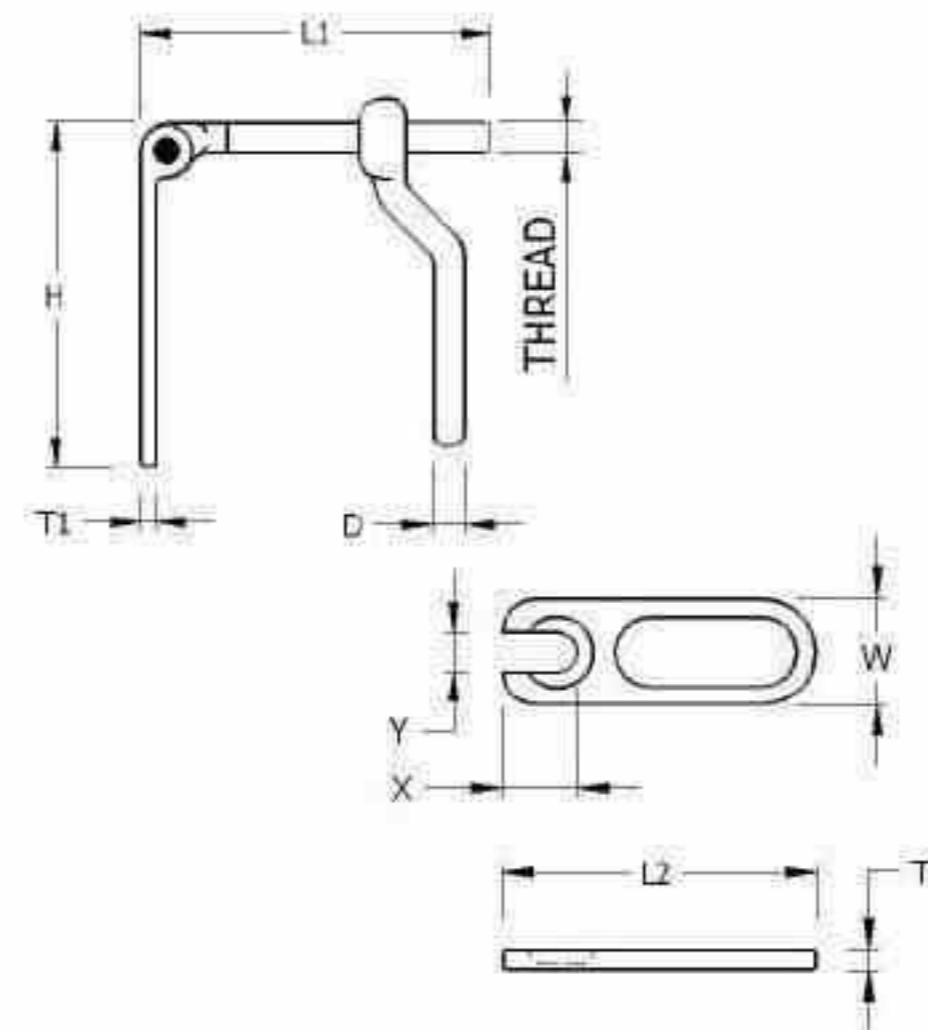

- All steel forged components
- Supplied as a pair
- Ramp fastener thread 3/8" Acme
- Finish: Self Colour



PART NUMBER	L1	L2	H	T1	T2	W	X	Y	KGS
236036	175	145	165	10	8	50	34	17.5	4.98

Spring Loaded Retainer

- Manufactured in ERW steel tube
- Supplied with rubber door buffer
- Primarily left handed, but can be used either way
- Finish: BZP

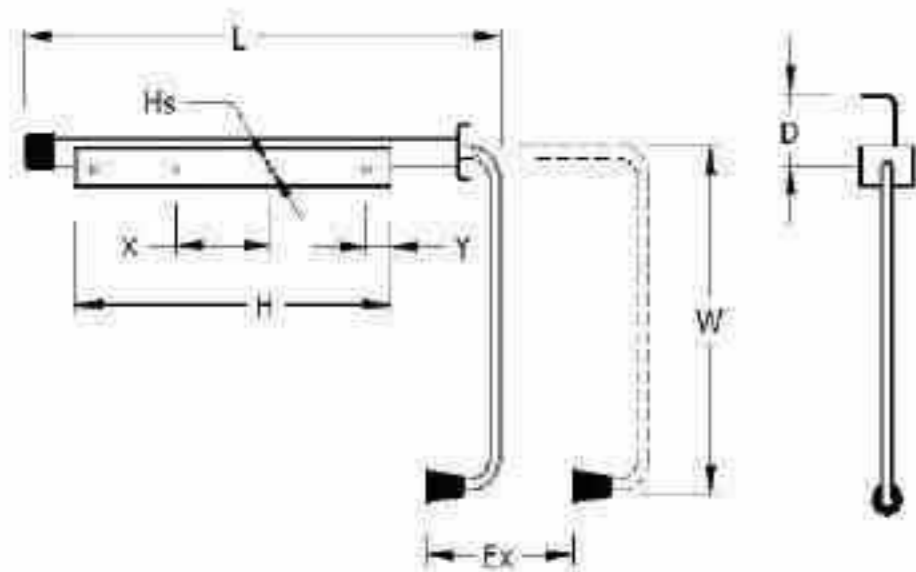

PART NUMBER	L	W	H	Ex	D	Hs	X	Y	KGS
235006	510	340	350	200	40	9	100	25	2.5

PVC Covered Cable Retainer

- 3mm galvanised cable
- PVC overlay in black or clear - prefix with the letter B or C to denote your choice (e.g. C235000)
- 75mm hook fitted as standard
- Various end fixings available (ask for details)

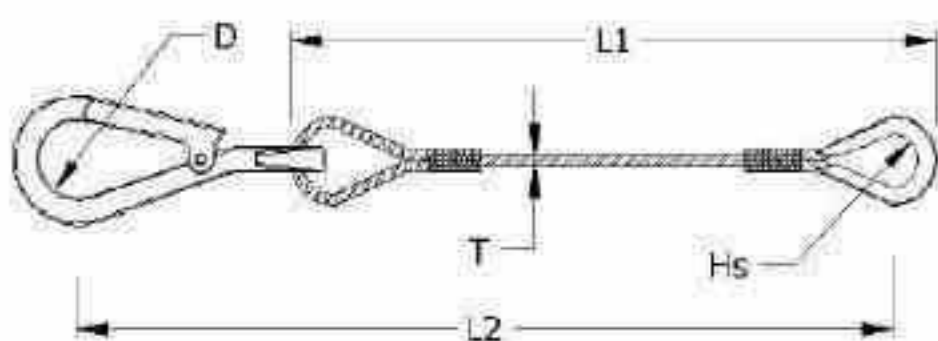

PART NUMBER	L1	L2	H	T	D	Hs	X	Y	KGS
235000	250	320	-	5	20	15	-	-	0.08
235001	300	370	-	5	20	15	-	-	0.09
235002	350	420	-	5	20	15	-	-	0.09
235003	400	470	-	5	20	15	-	-	0.10
235005	450	520	-	5	20	15	-	-	0.11

TIR Cable

- 6mm overall diameter cable EEC approved
- Maximum tensile strength: 180Kg/mm²
- Assembled to C&E EEC requirements
- Various lengths available



Cable End Set

- Sold as a kit



Part Number: 236024

PART NUMBER	WORKING LENGTH mtr	END STYLE	KGS
236019	30.4	TIR fixing 2 ends	1.52
236020	32.4	TIR fixing 2 ends	1.46
236021	34.4	TIR fixing 2 ends	1.82
236022	36.4	TIR fixing 2 ends	2.01
236023	40.4	TIR fixing 2 ends	2.02
236026	250	None	12.5
236025	16.7	TIR fixing 1 end	0.85
236027	500	None	25.0

Security Cable

- 6mm overall diameter cable
- Galvanised steel rope 7x7 construction
- Minimum failure strength 1770n/mm²
- Outer clear PVC coating for protection
- Various lengths available
- Optional end eye styles available



PART NUMBER	WORKING LENGTH mtr	END STYLE	KGS
236029	16.7	Soft eye 1 end	1.52
236030	34	Soft eye 1 end	2.50



Overcentre Buckle 50mm Webbing

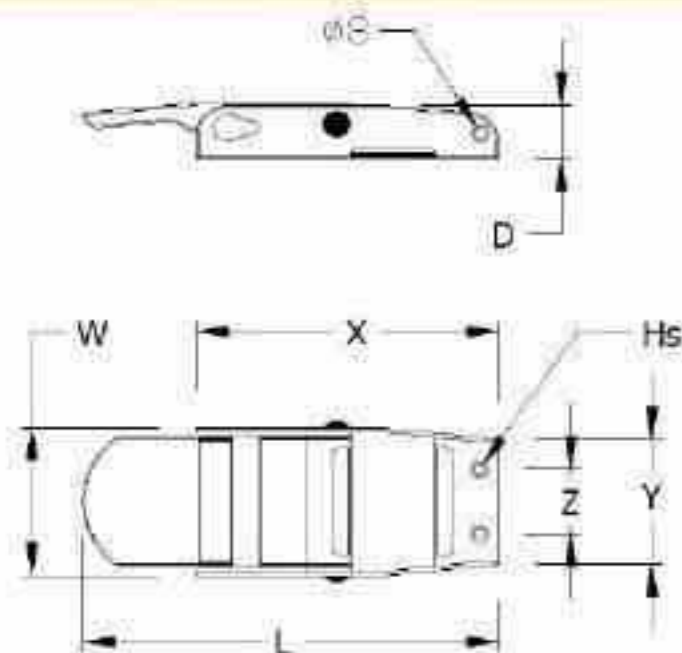

- Basic pressed buckle manufactured in mild steel or polished stainless
- Rated working load & finish:
 - 242036: 800 kgs - Mild Steel B2P to BS EN 12329:2000
 - 242035-52: 900 kgs - Stainless Polished 304 Grade



PART NUMBER	L	W	H	T	D	Hs	X	Y	Z	KGS
242035	180	64	-	2	22	7	130	54	28	0.225
242036	180	64	-	2	22	7	130	54	28	0.235
242052	155	64	-	2	22	7	115	54	28	0.213

Slimline Buckle 45mm Webbing

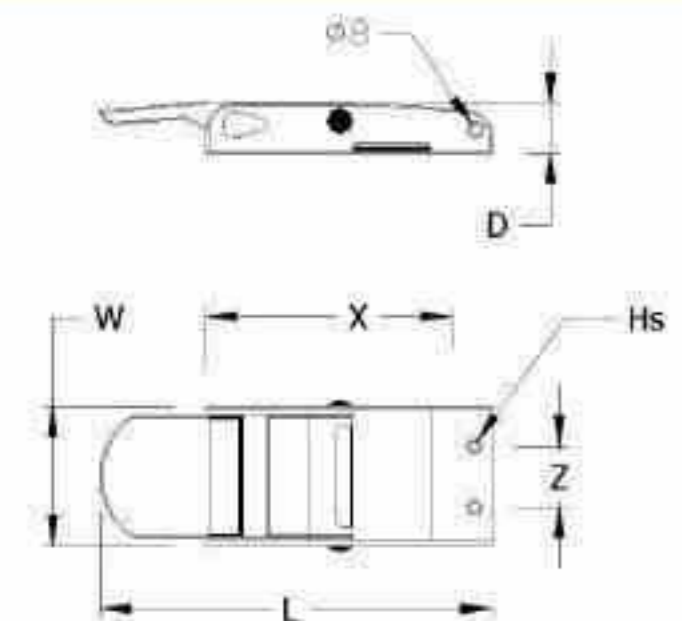

- Basic pressed buckle manufactured in stainless
- Optional body lengths available
- Rated working load: 900 kgs
- Finish: Stainless 304 Polished



PART NUMBER	L	W	H	T	D	Hs	X	Y	Z	KGS
242048	146	57	-	2	20	28	115	-	28	0.195
242049	172	57	-	2	20	28	128	-	28	0.225

Pozi-Plas Overcentre Buckle 50mm Webbing

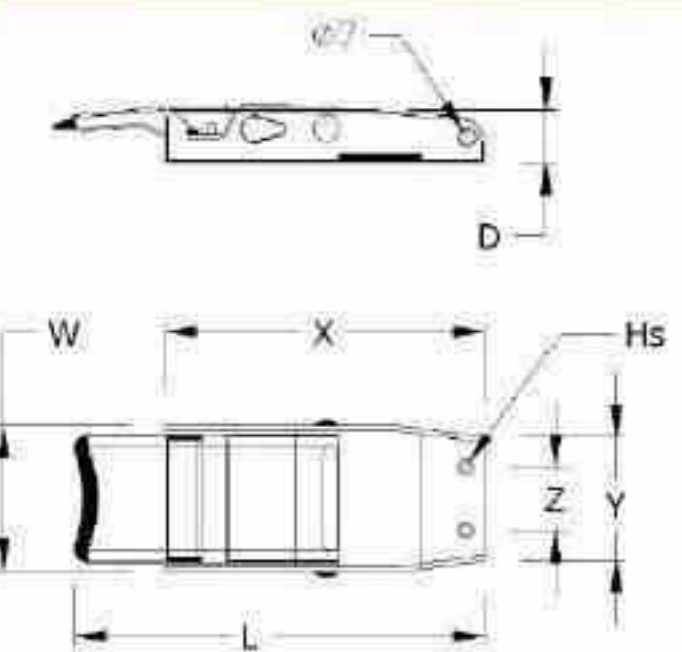

- Steel pressed body
- Over-centre tensioning
- Unique high density plastic locking mechanism
- Rated working load: 1100 kgs
- Finish: Stainless 304 Polished



PART NUMBER	L	W	H	T	D	Hs	X	Y	Z	KGS
242050	180	65	-	2	22	7	140	56	28	0.238



Pull Release Buckle 50mm Webbing

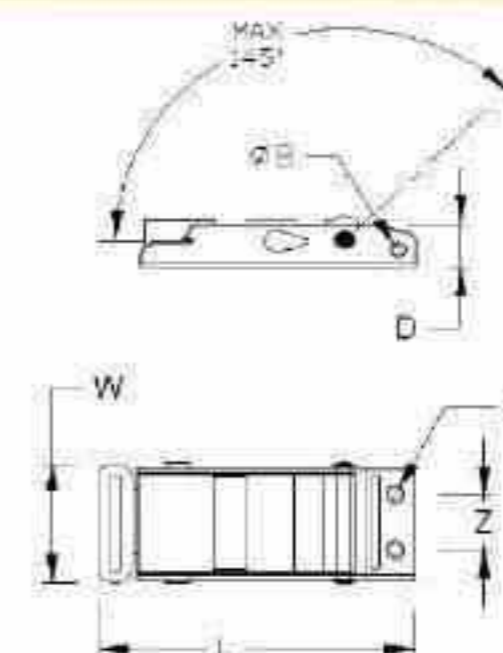

- Steel pressed body
- Positive sprung locking mechanism
- Optional stainless or plastic outer roller
- Rated working load:
 - 242038: 1100 kgs Plastic Roller
 - 242039: 1400 kgs Stainless Roller
- Finish: Stainless 304 Polished



PART NUMBER	L	W	H	T	D	Hs	X	Y	Z	KGS
242038	145	60	-	2	22	7	-	-	28	0.275
242039	145	60	-	2	22	7	-	-	28	0.300

Push Release Buckle 45mm Webbing

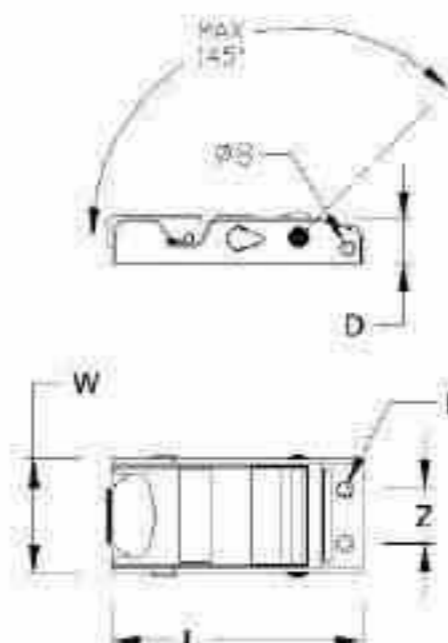

- Steel pressed body
- Positive sprung locking mechanism
- Rated working load: 1100 kgs
- Finish: Stainless 304 Polished



PART NUMBER	L	W	H	T	D	Hs	X	Y	Z	KGS
242034	138	57	-	2	23	7	-	-	28	0.35

Tysafe Buckle 50mm Webbing

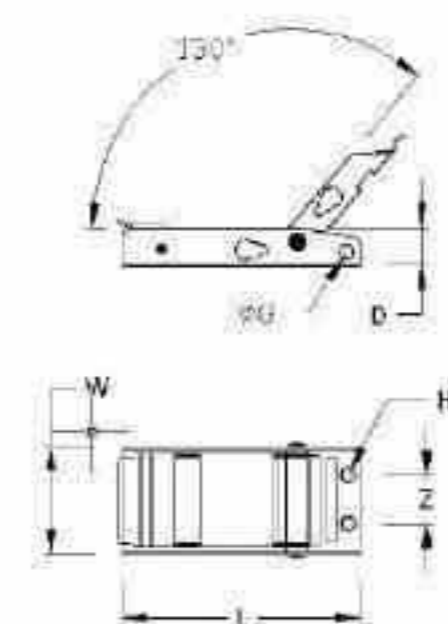

- Steel pressed body
- Captive locking mechanism
- Rated working load:
 - 242037: 1200 kgs Plastic Roller
 - 242056: 1200 kgs Stainless Roller
- Finish: Stainless 304 Polished



PART NUMBER	L	W	H	T	D	Hs	X	Y	Z	KGS
242037	138	62	-	2	22	7	-	-	28	0.32
242056	138	62	-	2	22	7	-	-	28	0.34



Bottom Strap with Rave Hook

- Polyester webbing - 50mm width
- BDMS bar 10mm diameter
- Plated to BS EN 12329:2000
- Working length 860mm
- Non-standard options available

PART NUMBER	L	W	H	T	D	Hs	X	Y	Z	KGS
242007	860	50	-	-	-	-	-	-	-	0.195



Internal Strap with Rave Hook & Snap Hook

- Polyester webbing - 50mm width
- Assembly supplied with overcentre buckle, rave hook and snap hook
- Zinc plated parts to BS EN 12329:2000
- Working length adjustable - max 4.88 mtrs
- Non-standard options available

PART NUMBER	L	W	H	T	D	Hs	X	Y	Z	KGS
242005	4880	50	-	-	-	-	-	-	-	0.730



Pressed Rave Hook

- 50 x 65 x 3mm thk pressed steel
- Stainless steel 304
- Zinc plated (BS EN 12329:2000) version optional; please enquire

PART NUMBER	L	W	H	T	D	Hs	X	Y	Z	KGS
242076	50	65	-	3	-	-	-	-	-	0.13



Closed Rave Hook

- BDMS bar 10mm diameter
- Zinc Plated to BS EN 12329:2000

PART NUMBER	L	W	H	T	D	Hs	X	Y	Z	KGS
242043	-	-	-	-	-	-	-	-	-	0.135

ID-3

Tel: 86-574-82815295/82815295
Web: jlhardware.com

Fax: 86-574-82815296
E-mail: sales@jlhardware.com



Waisted Ring - Narrow

- 40 x 75 x 6mm thk steel
- Zinc plated

PART NUMBER	L	W	H	T	D	Hs	X	Y	Z	KGS
242074	75	40	-	6	-	-	-	-	-	-



Waisted Ring - Wide

- 60 x 75 x 6mm thk steel
- Zinc plated

PART NUMBER	L	W	H	T	D	Hs	X	Y	Z	KGS
242075	75	60	-	6	-	-	-	-	-	-



Twin Fix Sandwich Plate Assembly

- 50 x 25

PART NUMBER	L	W	H	T	D	Hs	X	Y	Z	KGS
242068	25	50	-	-	-	-	-	-	-	-



Twin Fix Plate

- Complete with nyloc nuts
- Available in two sizes

PART NUMBER	L	W	H	T	D	Hs	X	Y	Z	KGS
242065	-	-	-	-	M6 x 16	-	-	-	-	-
242066	-	-	-	-	M6 x 20	-	-	-	-	-



Twin Fix Clamp Plate

PART NUMBER	L	W	H	T	D	Hs	X	Y	Z	KGS
242067	-	-	-	-	-	-	-	-	-	-

Tel: 86-574-82815295/82815295
Web: jlhardware.com

Fax: 86-574-82815296
E-mail: sales@jlhardware.com

ID-4

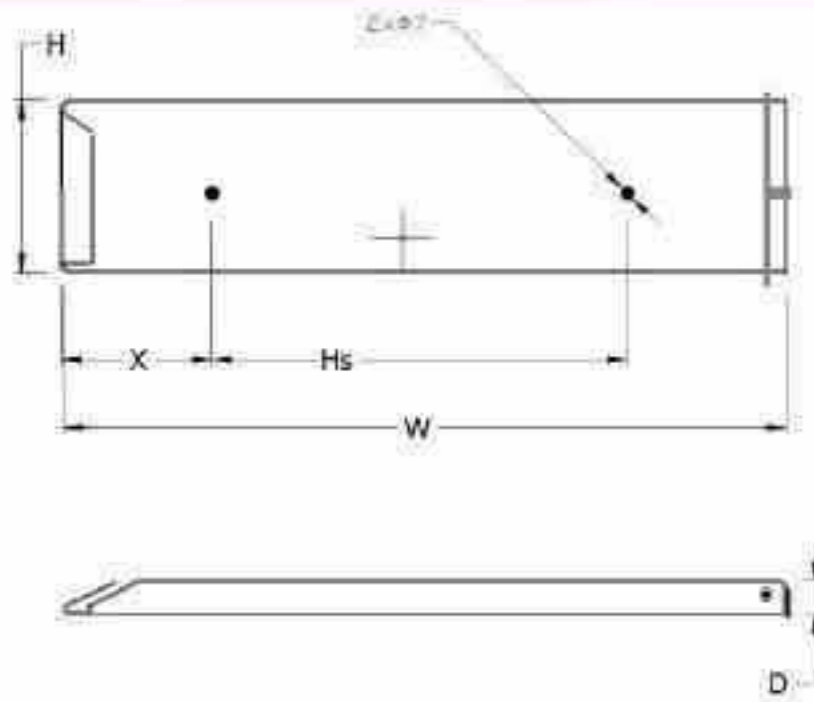

UK Long Number Plate Holder

- Spring loaded plate holder
- Designed for car type long number plates
- Supplied with fixing holes
- Finish: EPC Powder Black



PART NUMBER	L	W	H	T	D	Hs	X	Y	KGS
248001	-	525	125	-	30	300	110	-	0.88

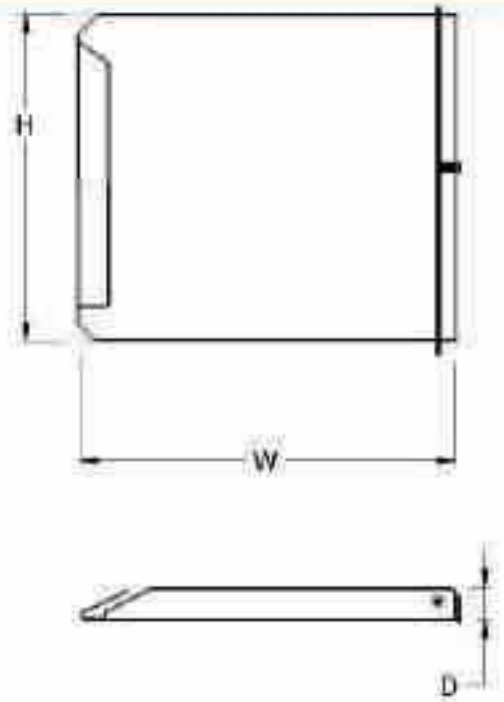

Commercial Square Number Plate Holder

- Spring loaded truck or trailer number plate holder
- Supplied blank - no fixing holes
- Finish: EPC Powder Black



PART NUMBER	L	W	H	T	D	Hs	X	Y	KGS
248002	-	290	250	-	30	-	-	-	1.10

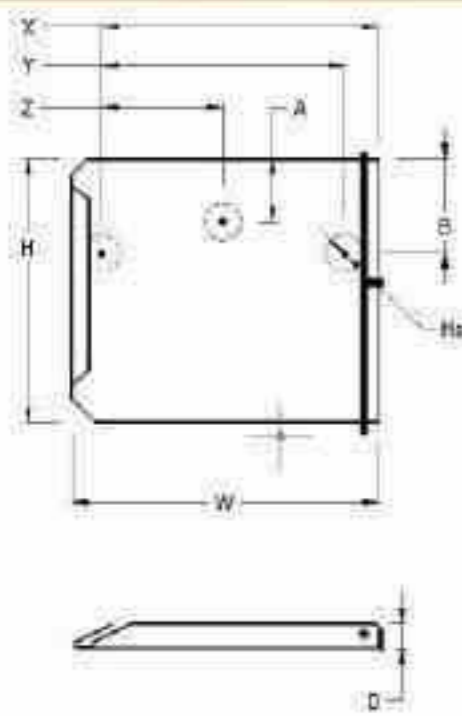

UK Square Number Plate Holder

- Spring loaded plate holder
- Suitable for commercial type number plates
- Supplied with fixing holes
- Finish: EPC Powder Black



PART NUMBER	L	W	H	T	D	Hs	X	Y	KGS
248004	-	295	260	-	35	7	32	114	0.75



UK Deep & Slimline Number Plate Holder

- Spring loaded plate holder
- Designed for variable height type number plates
- Supplied with fixing holes
- Finish: Galvanised

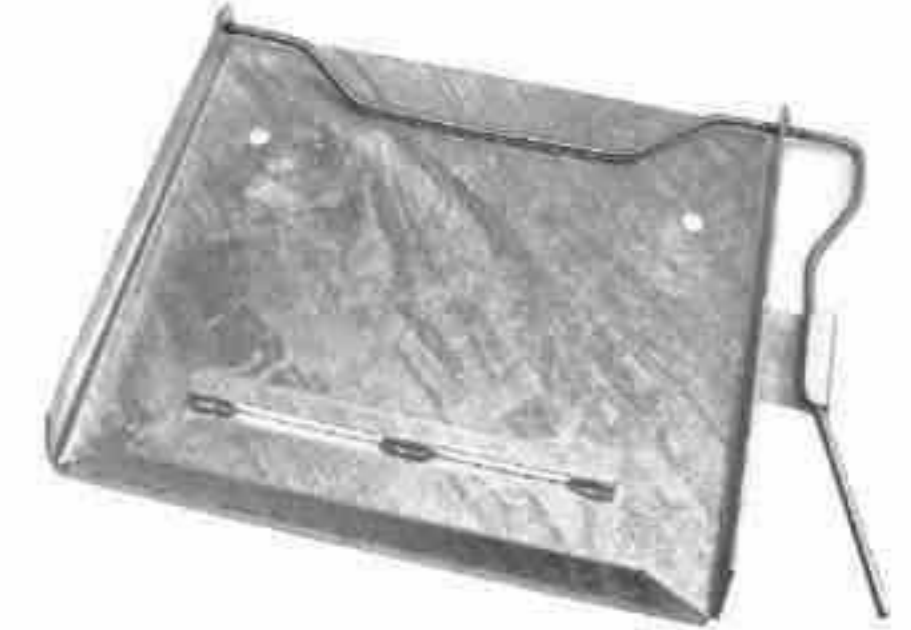
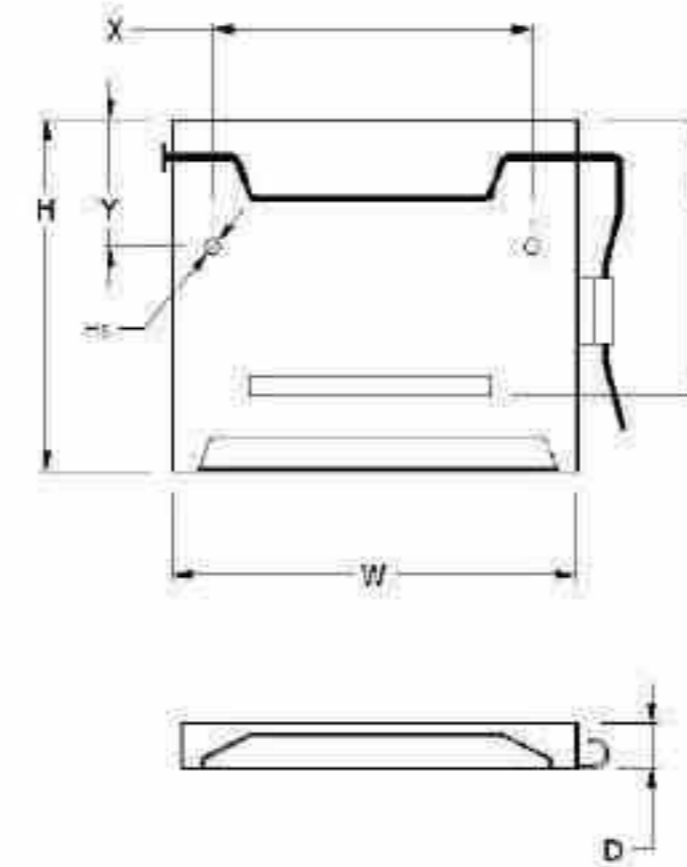

PART NUMBER	L	W	H	T	D	Hs	X	Y	KGS
248003	220	306	270	-	30	11	230	70	1.1

Deep Number Plate Holder

- Stainless steel spring mechanism
- Designed for single plate storage
- Supplied with fixing holes
- Finish: Galvanised

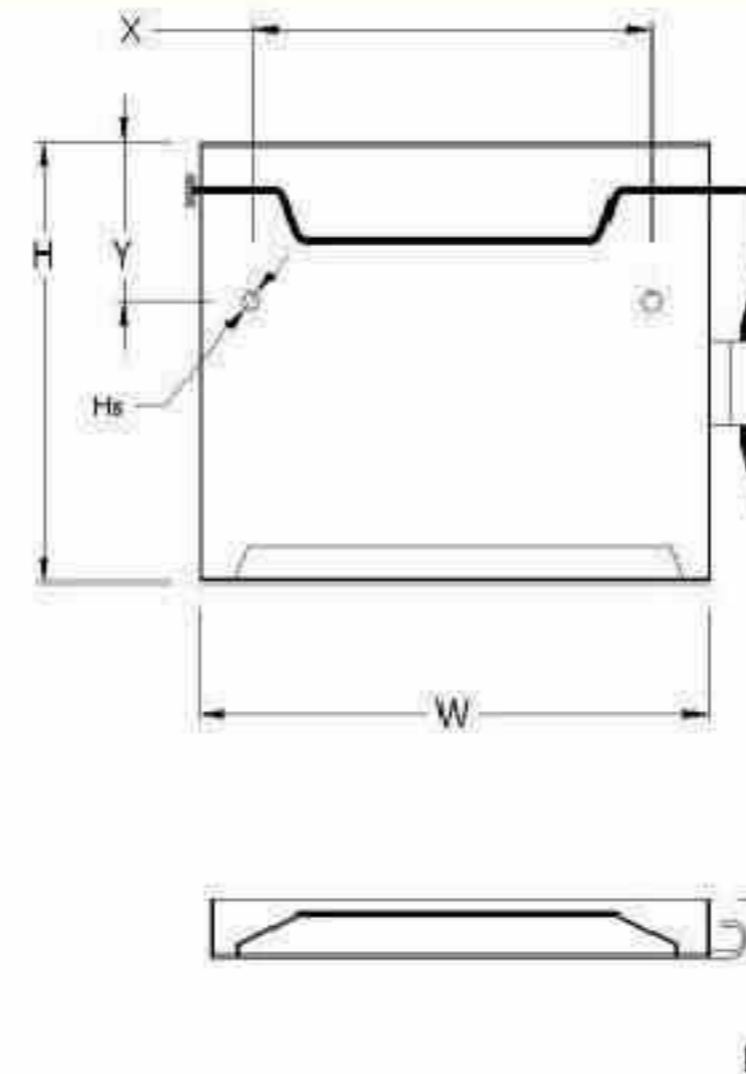

PART NUMBER	L	W	H	T	D	Hs	X	Y	KGS
248008	-	312	270	-	30	11	230	70	1.0

Cargo Winch

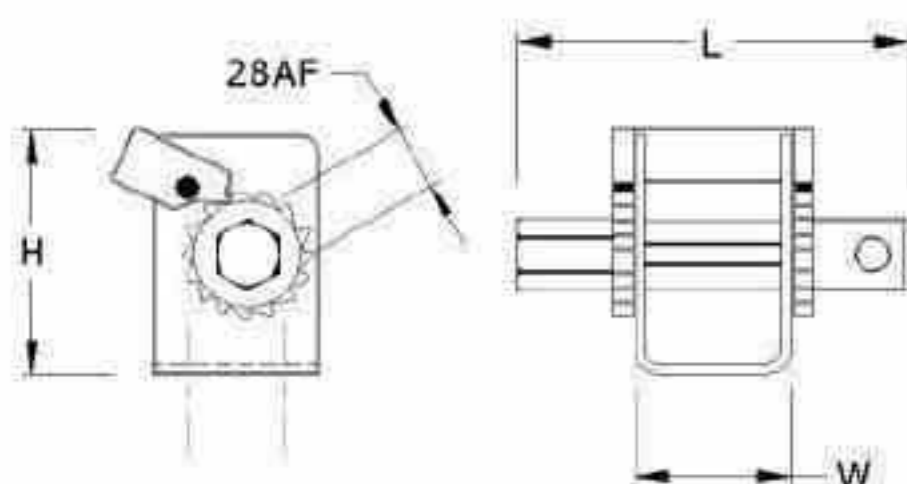

- Suitable for 50mm webbing straps
- Load rated to 1500 kgs
- 28mm hex end for Tommy Bar
- Fixing by means of 2 x 12mm dia holes / 40mm ctrs
- Finish: Spool - BZP; Body - EPC



PART NUMBER	L	W	H	T	D	Hs	X	Y	KGS
242011	160	65	100	4	-	12.5	32.5	40	1.63

Car Transporter Winch

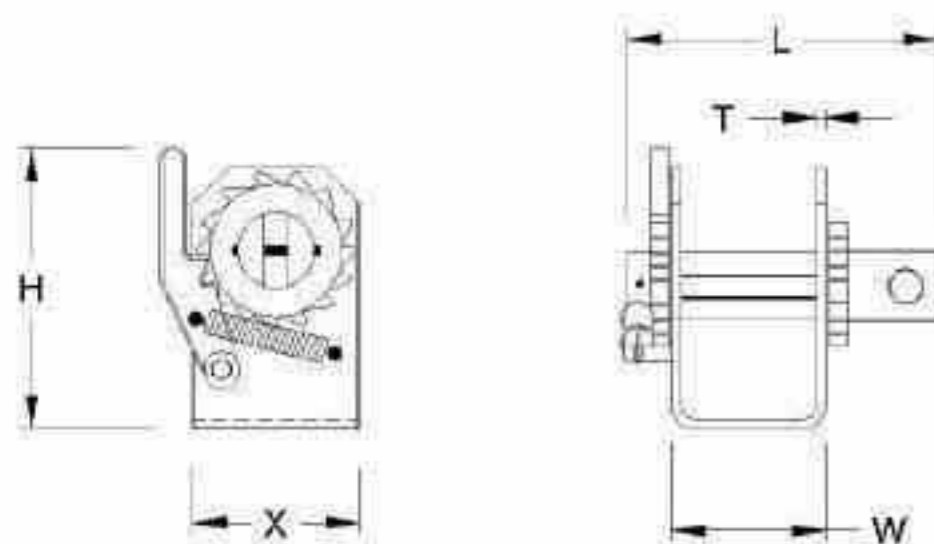

- Suitable for 50mm webbing
- Rated load capacity is 1500 kgs
- Fixing by means of a 12.5mm dia hole
- Fixing kit not supplied (for fixing kit, please ask for part 242002)
- Finish: ZYP



PART NUMBER	L	W	H	T	D	Hs	X	Y	KGS
242000 L/H	120	62	115	4	-	12.5	65	-	1.56
242001 R/H	120	62	115	4	-	12.5	65	-	1.56

Strap Winch

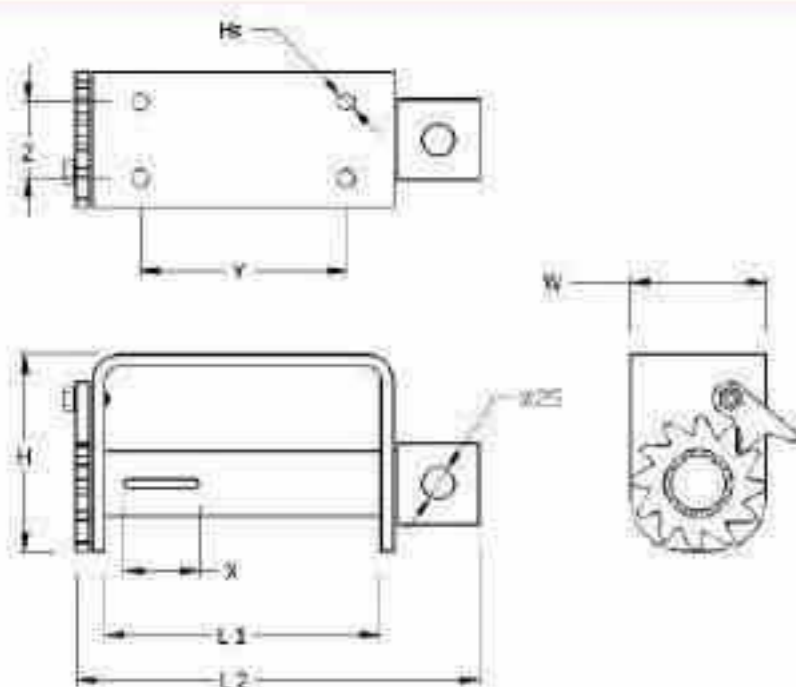

- All steel construction
- Supplied with securing holes for under-chassis mounting
- Suitable for webbing widths up to 50mm
- Finish: EPC Red



PART NUMBER	L	L1	L2	W	H	Hs	X	Y	Z	KGS
242061	250	200	294	100	145	13	55	150	56	5.2

Forged Eye-Bolt and Ring

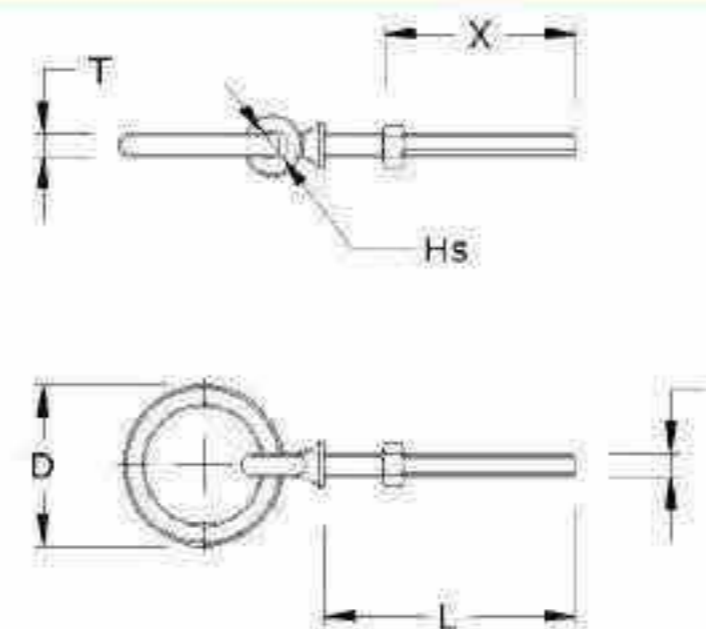

- Metric shank thread
- Supplied with a plain nut and support washer
- Finish: Natural



PART NUMBER	L	W	H	T	D	Hs	X	Y	KGS
242022	110	-	-	9.5	70	12.7	55	M10	0.22
242017	155	-	-	9.5	105	12.7	76	M16	0.28

Cargo Ring

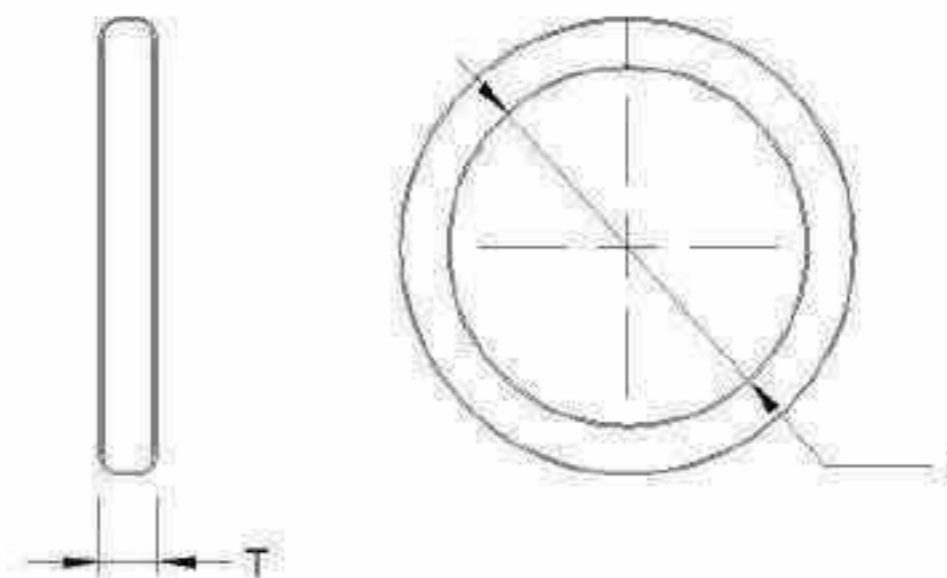

- Welded steel ring
- 75mm internal diameter
- 8mm thick
- Finish: BZP



PART NUMBER	L	W	H	T	D	Hs	X	Y	KGS
242021	-	-	-	8	75	-	-	-	1.124

Load Security Rope



- 10mm diameter rope
- Blue polypropylene
- Breaking load 3104 lbs (1424 kgs)
- Supplied in 3 working lengths

PART NUMBER	WORKING LENGTH mtrs (ft)	KGS
242024	220 (720)	24.9
242030	27.5 (90)	3.12
242031	36.5 (120)	4.15

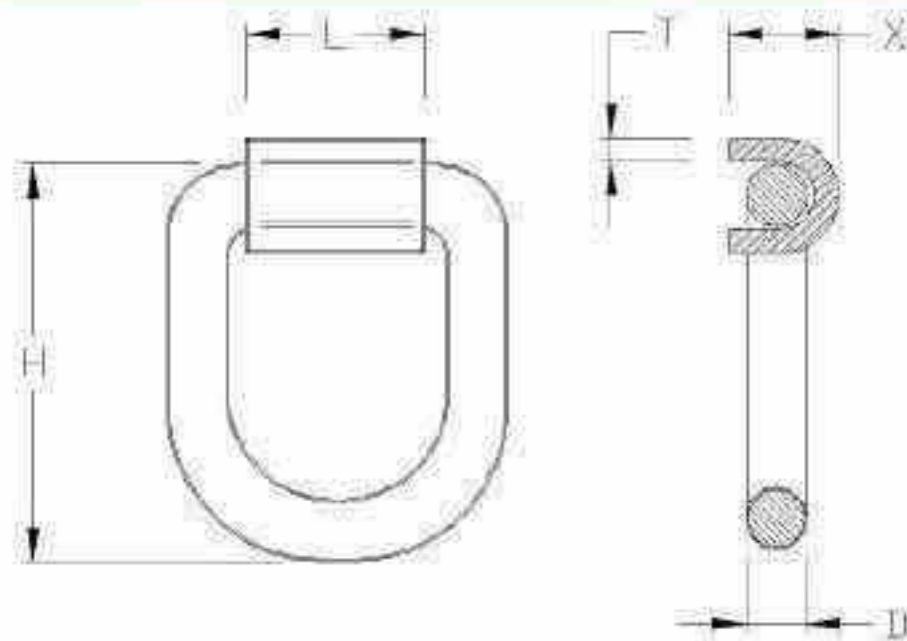

Ferry Shackle 'C' Type

- Manufactured in forged steel
- Designed for chassis lashing
- SWL:
 - 20 mm dia = 1.25 Tonnes
 - 23 mm dia = 2.25 Tonnes
 - 26 mm dia = 3.25 Tonnes
- Finish: Natural



PART NUMBER	L	W	H	T	D	Hs	X	Y	KGS
233043	75	-	135	10	20	-	38	-	1.35
233060	75	-	150	12	23	-	43	-	1.90
233061	75	-	165	15	26	-	48	-	2.20

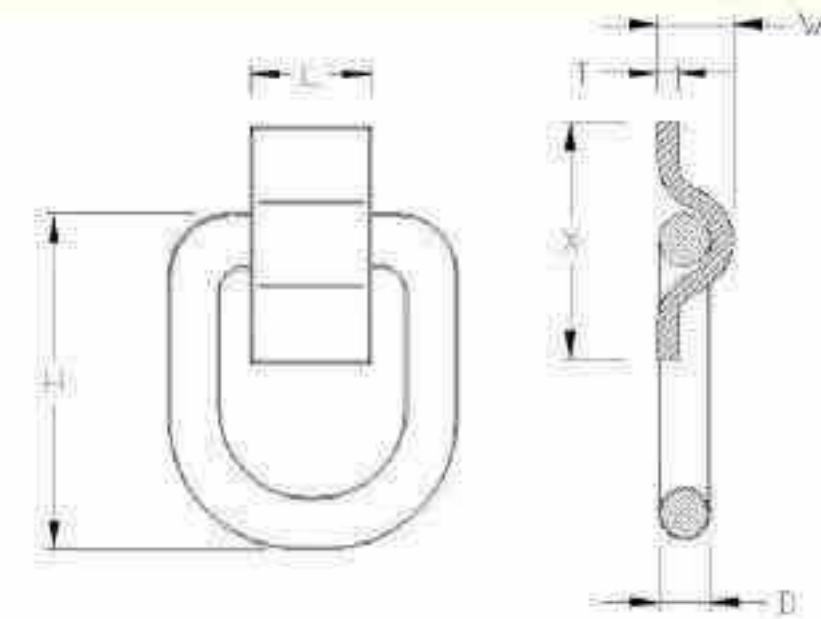

Ferry Shackle 'P' Type

- Manufactured in forged steel
- Designed for chassis lashing
- SWL:
 - 20 mm dia = 1.25 Tonnes
 - 23 mm dia = 2.25 Tonnes
 - 26 mm dia = 3.25 Tonnes
- Finish: Natural



PART NUMBER	L	W	H	T	D	Hs	X	Y	KGS
233058	75	38	135	10	20	-	120	-	1.42
233062	75	44	150	12	23	-	120	-	1.96
233063	75	52	165	15	26	-	120	-	2.26

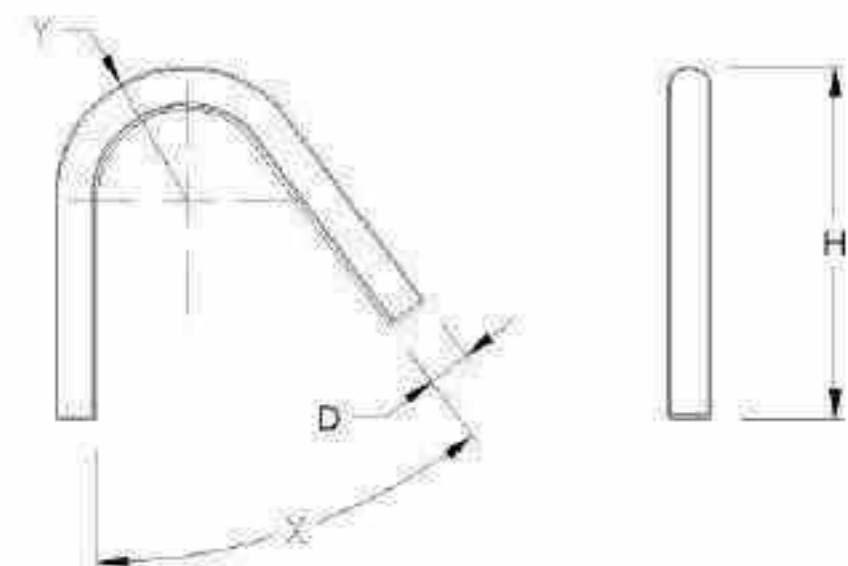

C-Weld-On Steel Rope Hook

- One size available from stock
- Other sizes may be available - please enquire
- Finish: Natural



PART NUMBER	L	W	H	T	D	Hs	X	Y	KGS
242019	-	-	60	-	16	-	37	60	0.19

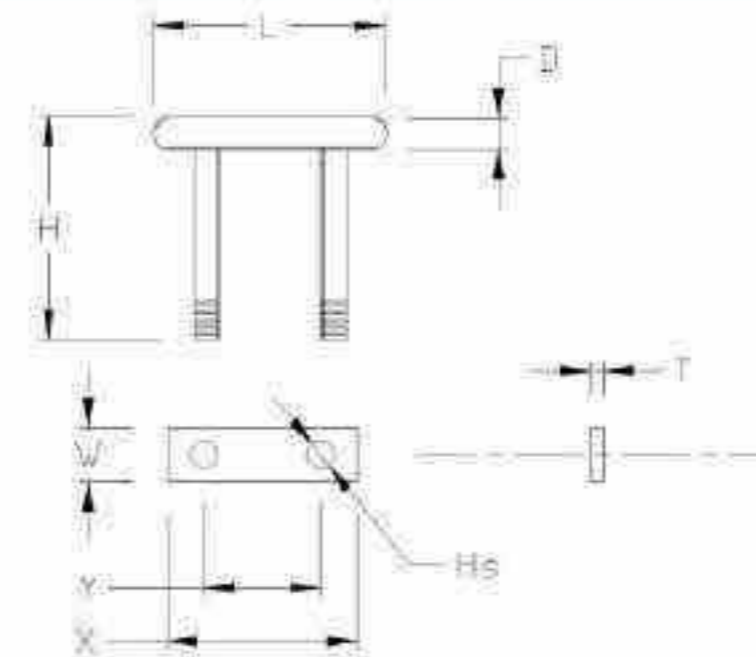

Rave Drop Down Lashing Fork

- Manufactured in forged steel
- Designed to be secured within side raves with a 'V' profile
- Supplied complete with backing plate and M12 nyloc nuts
- SWL: 2.5 Tonnes
- Finish: ZYP



PART NUMBER	L	W	H	T	D	Hs	X	Y	KGS
242029	105	25	115	6	15	13	90	55	0.44

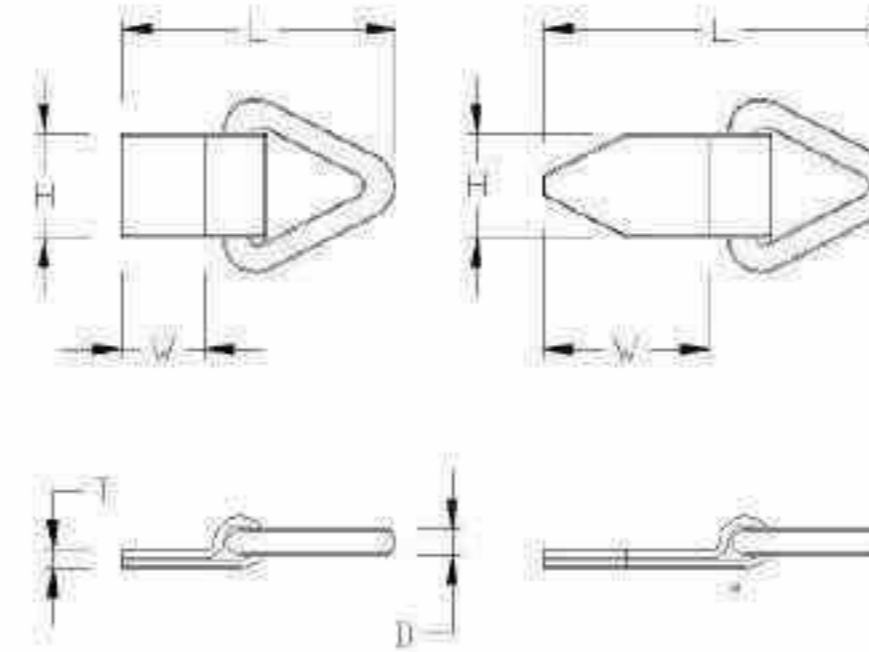

Triangular Lashing Ring with Plate

- Designed for welding to a vehicle chassis for load containment
- Long and short plate options
- SWL: 1 Tonne
- Finish: Ring - Galvanised; Plate - Natural



PART NUMBER	L	W	H	T	D	Hs	X	Y	KGS
242026	175	80	50	9	13.5	-	-	-	0.7
242028	135	40	50	9	13.5	-	-	-	0.5

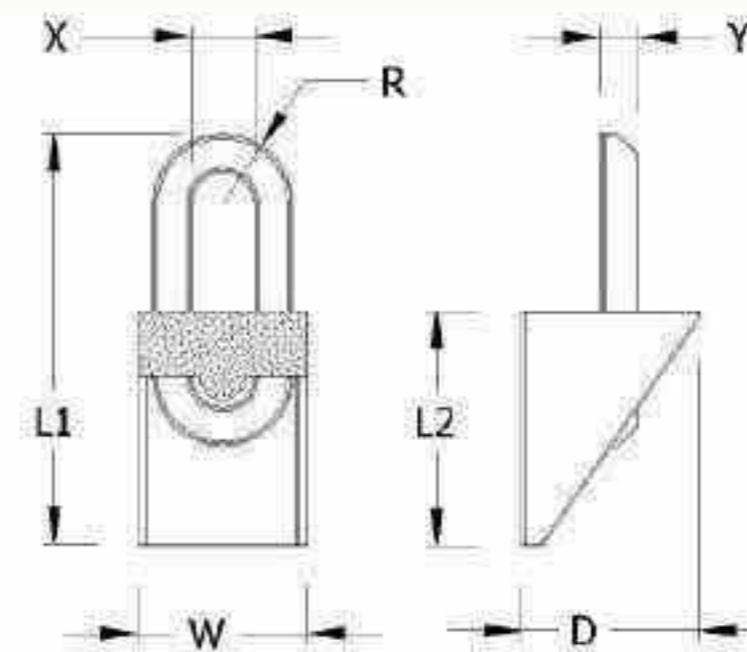

Under-Floor Lashing Ring

- Weld-in floor lashing ring
- Steel forged ring captive in a pressed steel body
- SWL: 2.5 Tonnes
- Finish: Natural



PART NUMBER	L	W	H	T	D	Hs	X	Y	KGS
242053	162	90	65	68	4	55	25	15	0.88

Commercial Ratchet Strap Assembly

- Manufactured to BS EN12195-5 in 100% polyester webbing
- Ratchet strap mechanism supplied in steel and finished in ZYP
- Supplied with claw end as standard
- Delta and rave ends are optional

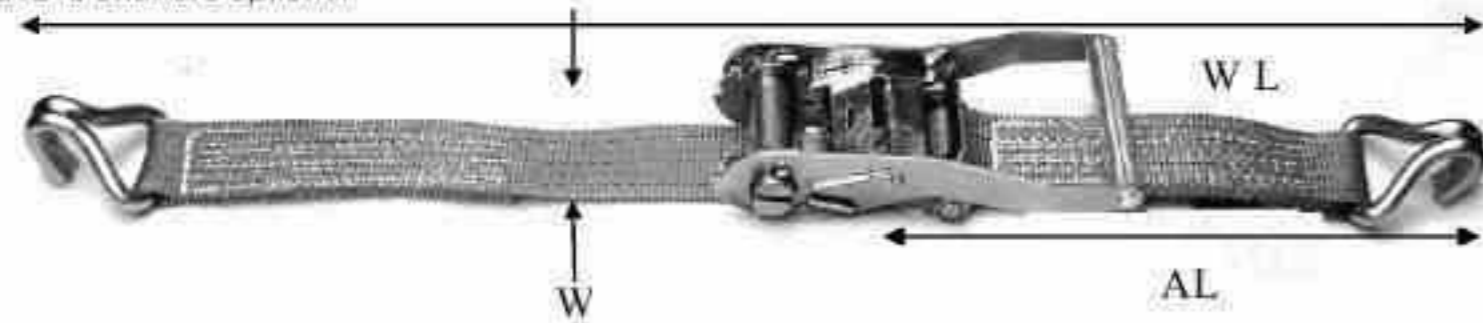

PART NUMBER	AL (mm)	WL (mtrs)	W (mm)	RAS (kgs)	MBS (kgs)	KGS
242003	500	8	50	2500	5000	2.60
242004	500	10	50	2500	5000	2.70
242020	220	5	25	500	1000	0.75
242023	290	5	35	1250	2500	1.25
242027	500	12	50	2500	5000	3.10

Replacement Binder



PART NUMBER	END STYLE	WEBBING WIDTH (mm)	KGS
242040	CLAW END	50	-
242044	CLAW END	35	-
N/A	CLAW END	25	-

Replacement Strap



PART NUMBER	END STYLE	WEBBING TYPE	KGS
242041	CLAW END	10mtrs x 50mm	-
242042	CLAW END	8mtrs x 50mm	-
242045	CLAW END	5mtrs x 35mm	-

Plant-On Lock

- Heavy duty spring loaded overcentre lock
- Complete with catch plate
- Overall depth of lock: 30mm
- Finish: Lock - BZP; Catch - Self Colour

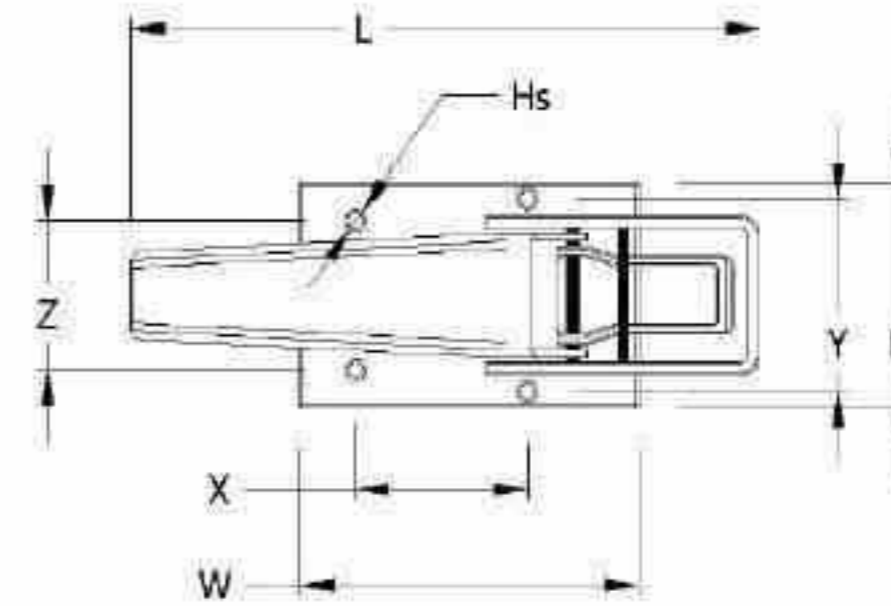

PART NUMBER	L	W	H	T	D	Hs	X	Y	Z	KGS
243002	260	140	88	-	-	9	70	75	58	1.30

Recessed Overcentre Lock

- Surface mounted recessed lock
- Complete with catch plate
- Recessed depth: 25mm
- Finish: Body - BZP; Catch - Self Colour

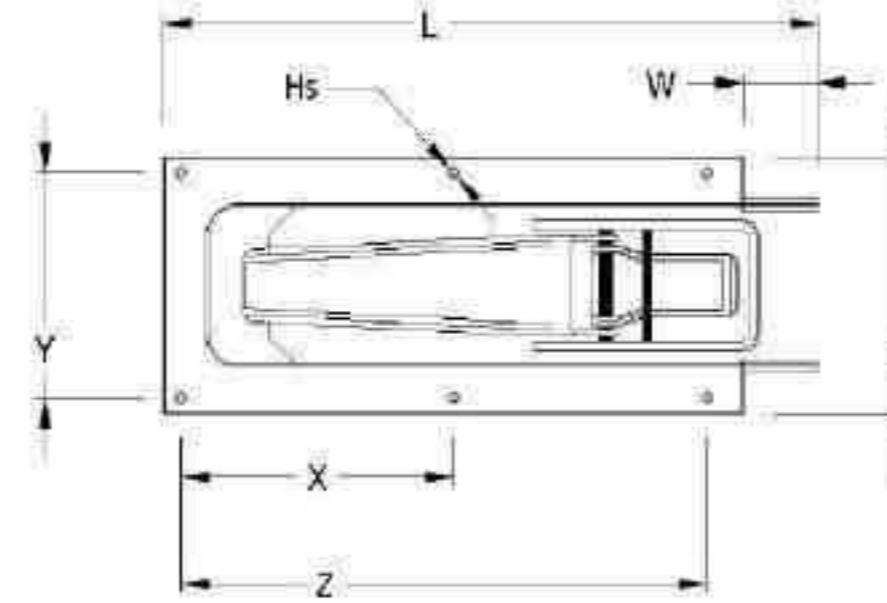

PART NUMBER	L	W	H	T	D	Hs	X	Y	Z	KGS
243003	330	38	120	2	-	5.5	138	100	266	1.70

Door Blade Assembly

- Heavy duty 4 mm thick door hinge
- Nylon bushed
- Complete with high tensile bolt and nyloc nut
- Also available in stainless steel
- Finish: Zinc Plated

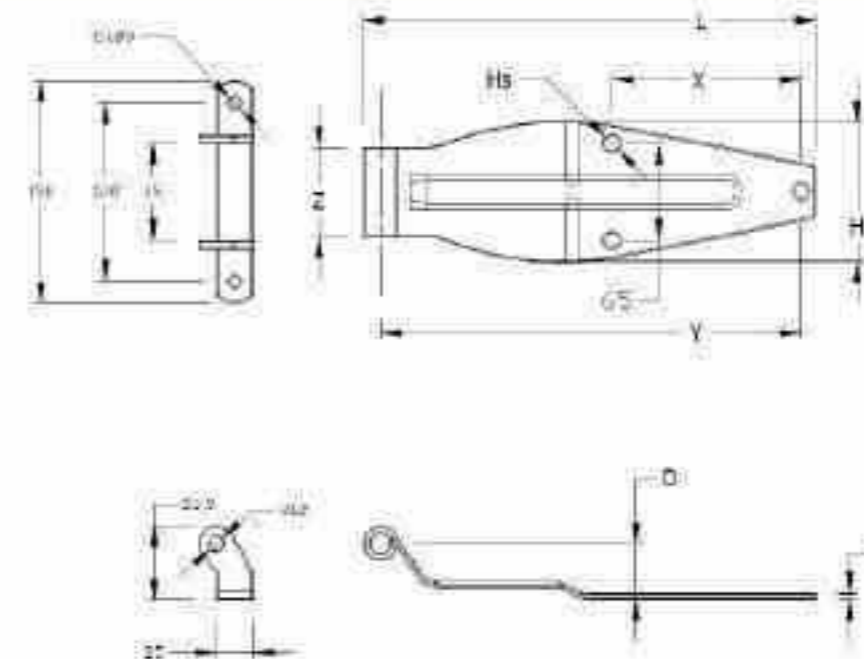

PART NUMBER	L	W	H	T	D	Hs	X	Y	Z	KGS
243000	295	-	90	4	38	10.5	130	285	63	1.22

Flush Fit Panel Lock

- Designed to be surface mounted and recessed
- Rubber gasket to prevent water ingress
- Complete with 2 keys
- Cut-out required: 115 mm x 65 mm
- Finish: Stainless 314 Polished

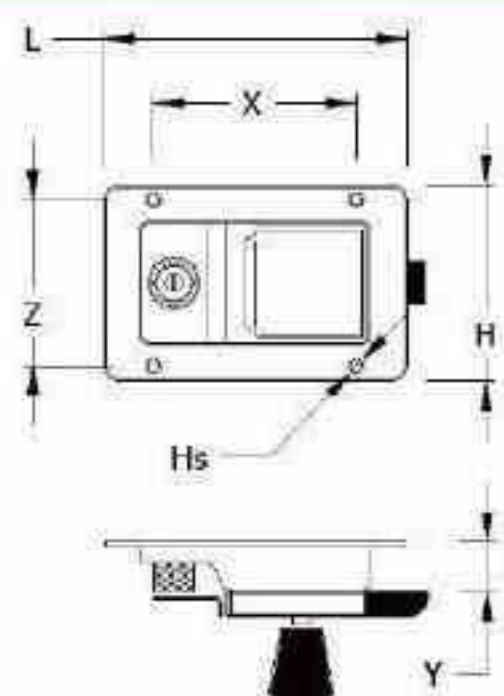

PART NUMBER	L	W	H	T	D	Hs	X	Y	KGS
243004	140	-	90	1.2	-	5.5	95	20	0.46

Flush Fit Tee Handle Lock

- Surface mounted front pressed plate
- Steel plated mechanism
- Complete with 2 keys
- Cut-out required: 92 mm x 70 mm
- Finish: Plate - Stainless 314 Polished; Mechanism - J5500 Plated Steel

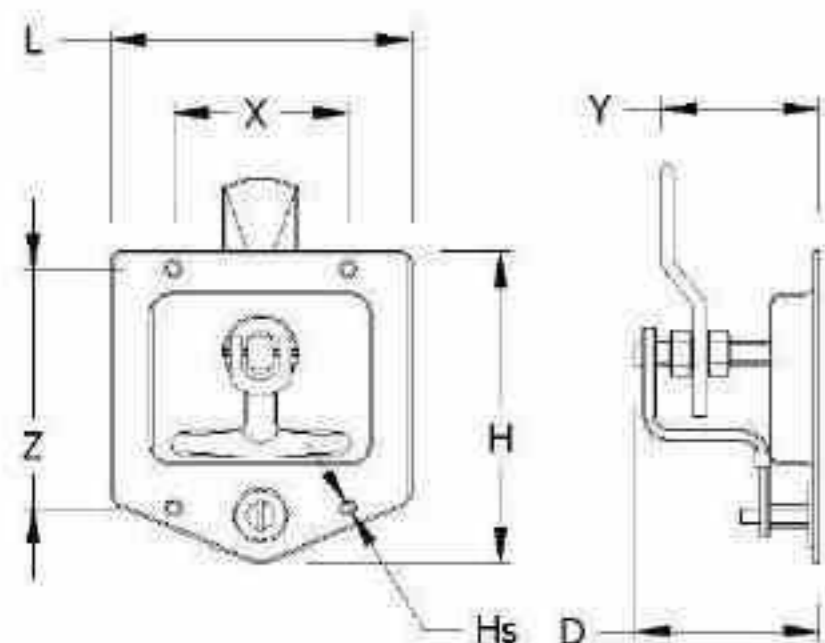

PART NUMBER	L	W	H	T	D	Hs	X	Y	KGS
243005	120	-	145	1.2	70	7	76	60	0.72

Hinge Assembly

- Heavy duty 4 mm thick stainless hinge
- Pressed spun pivot pin
- Finish: Stainless 314 Polished

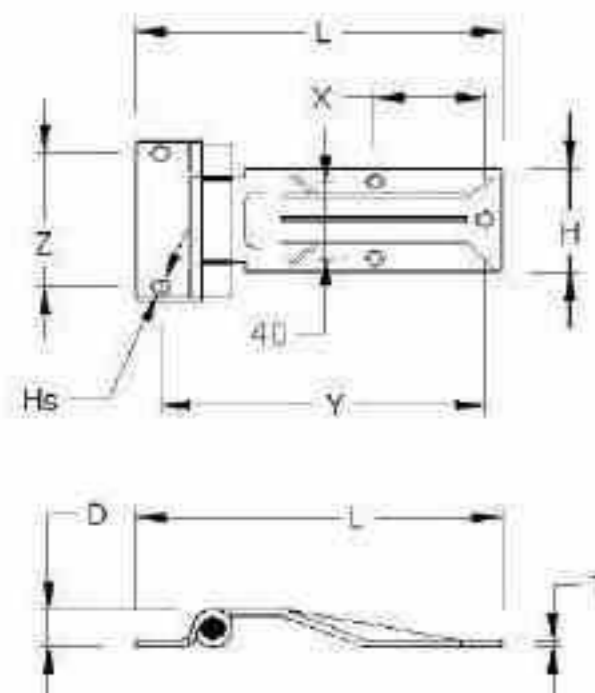

PART NUMBER	L	W	H	T	D	Hs	X	Y	Z	KGS
243006	180	-	55	4	25	8.5	55	157	70	0.40

Un-Bushed Door Gear Set

- 20-27 mm suitability with good gather and anti-racking properties
- Cam and keepers are investment castings and are universal
- Suitable for left and right handed doors
- Handle is forged
- Comes with hub, catch retainer and spacer
- Finish: Zinc Plated - BS EN 12329:2000

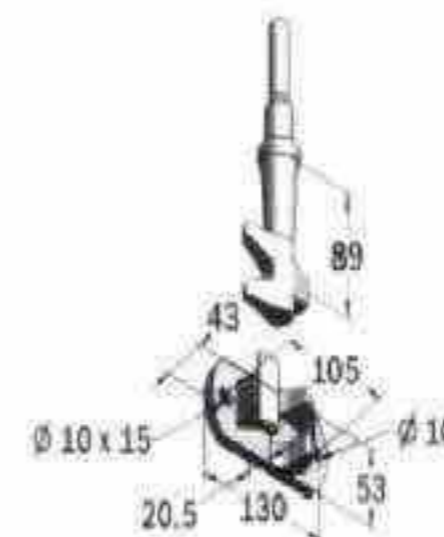
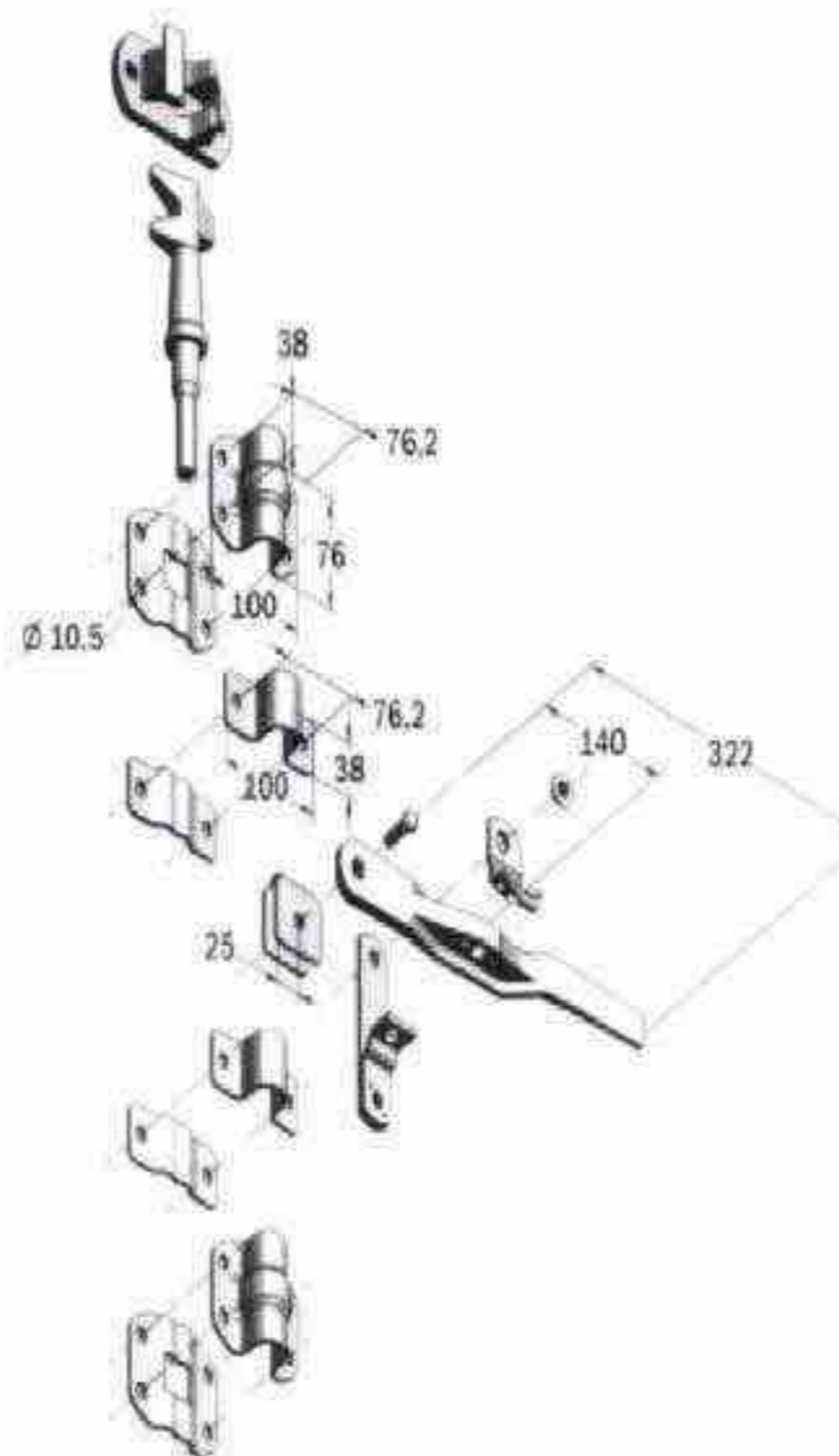

PART NUMBER	KGS
243001	5.7

contents

- wing stays - 2A
- wheel carriers - 2B
- coupling boxes - 2C
- landing gear - 2D
- pull-out steps - 2E
- rollers & buffers - 2F
- side guard supports - 2G

chassis components

Mono-Bolt Wing Stay 'C' Type

- Steel tubular construction
- Supplied with nyloc nut, washer and plastic end cap
- Finish: Galvanised or EPC Black - please enquire

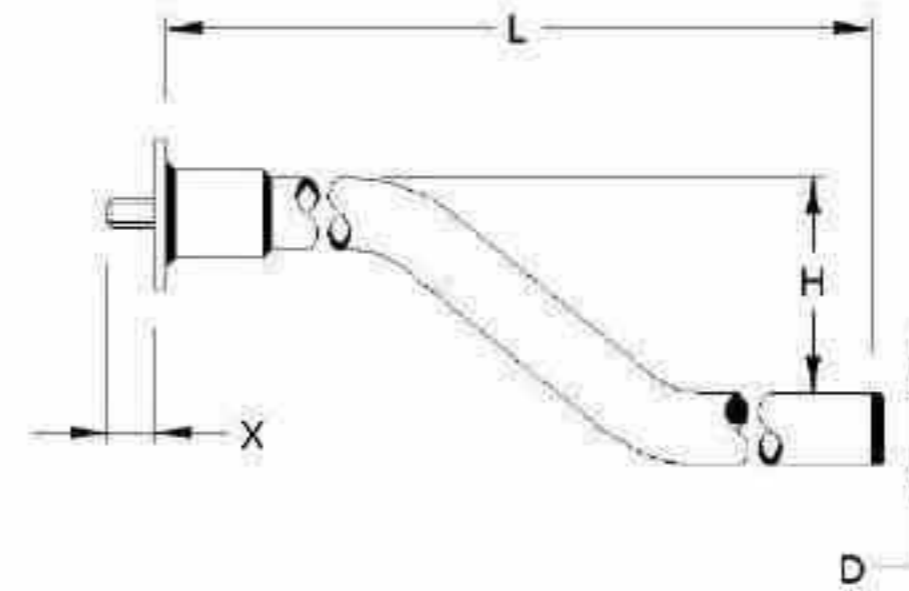

PART NUMBER	L	W	H	T	D	Hs	X	Y	KGS
233044	760	-	100	-	34	16.5	50	-	2.5
233001	670	-	100	-	34	16.5	50	-	2.3
233003	570	-	100	-	34	16.5	50	-	1.9

Mono-Bolt Wing Stay 'S' Type

- Steel tubular construction
- Supplied with nyloc nut, washer and plastic end cap
- Finish: Galvanised or EPC Black - please enquire

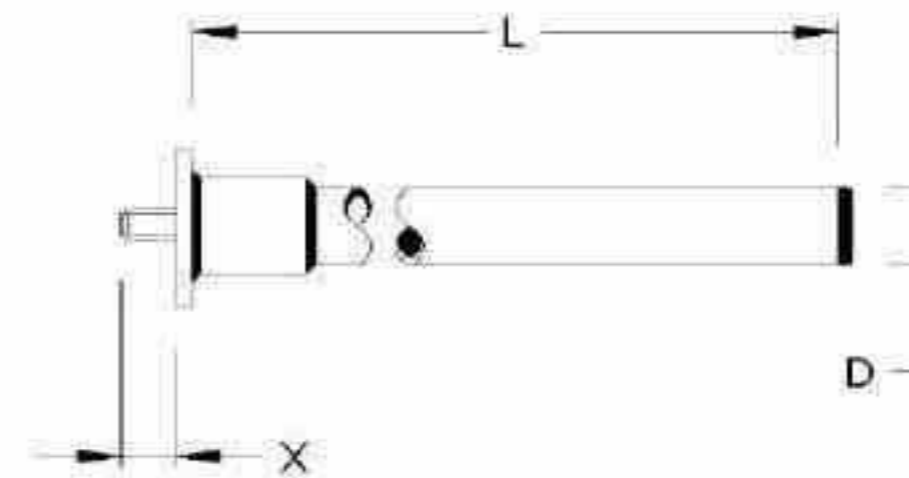

PART NUMBER	L	W	H	T	D	Hs	X	Y	KGS
233059	760	-	-	-	34	16.5	50	-	2.4
233004	670	-	-	-	34	16.5	50	-	2.1
233006	570	-	-	-	34	16.5	50	-	1.8

Tri-Bolt Wing Stay 'C' Type

- Steel tubular construction
- 3 hole fixing
- Supplied complete with plastic end cap
- Finish: Galvanised or EPC Black - please enquire

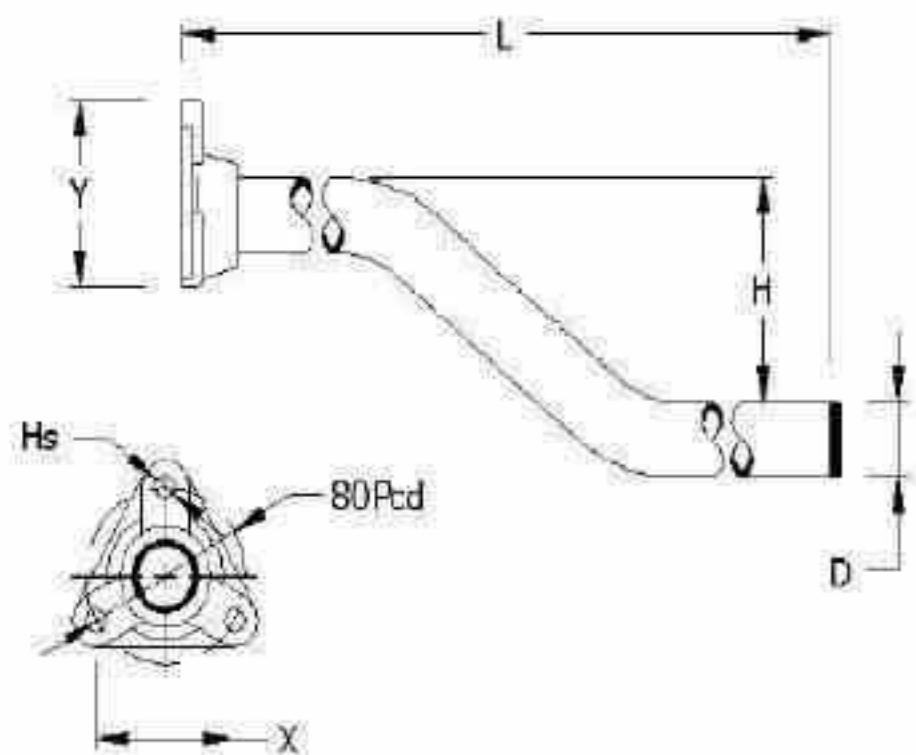

PART NUMBER	L	W	H	T	D	Hs	X	Y	KGS
233002	760	-	100	-	34	10.5	68	85	2.4
233048	670	-	100	-	34	10.5	68	85	2.2
233017	800	-	120	-	42	10.5	68	85	2.4
233018	700	-	120	-	42	10.5	68	85	2.3

Tri-Bolt Wing Stay 'S' Type

- Steel tubular construction
- 3 hole fixing
- Supplied complete with plastic end cap
- Finish: Galvanised or EPC Black - please enquire

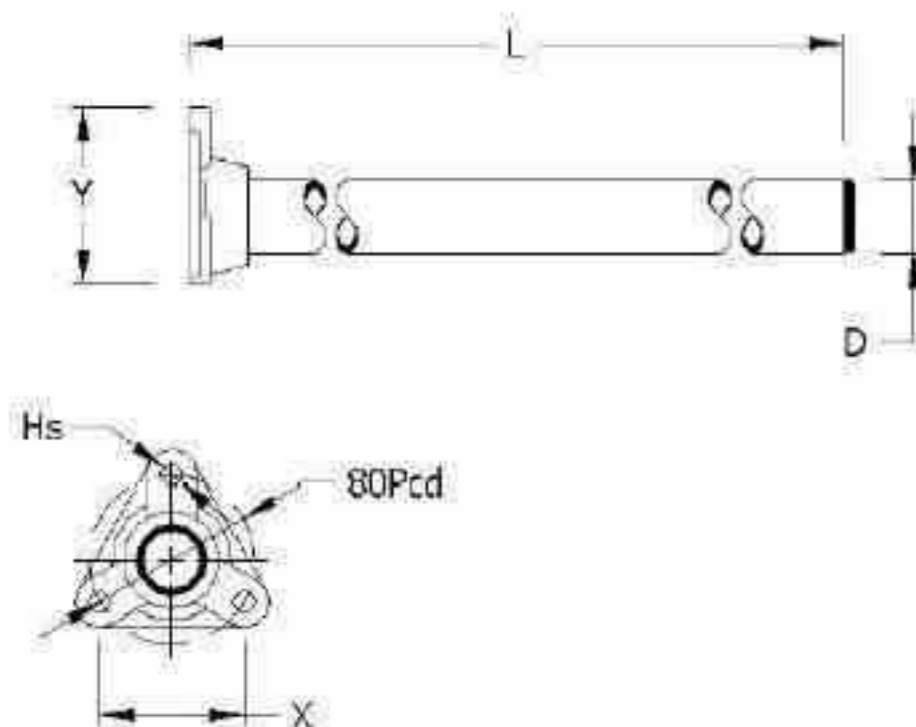

PART NUMBER	L	W	H	T	D	Hs	X	Y	KGS
233007	760	-	-	-	34	10.5	68	85	2.3
233049	670	-	-	-	34	10.5	68	85	1.9
233019	760	-	-	-	42	10.5	68	85	2.4
233020	670	-	-	-	42	10.5	68	85	2.3

Wing Stay Tunnel Pressing

- Manufactured in 1mm Zintec steel
- Mounting pattern is 6 hole arrangement
- Finish: Zinc Spangled Galvanised

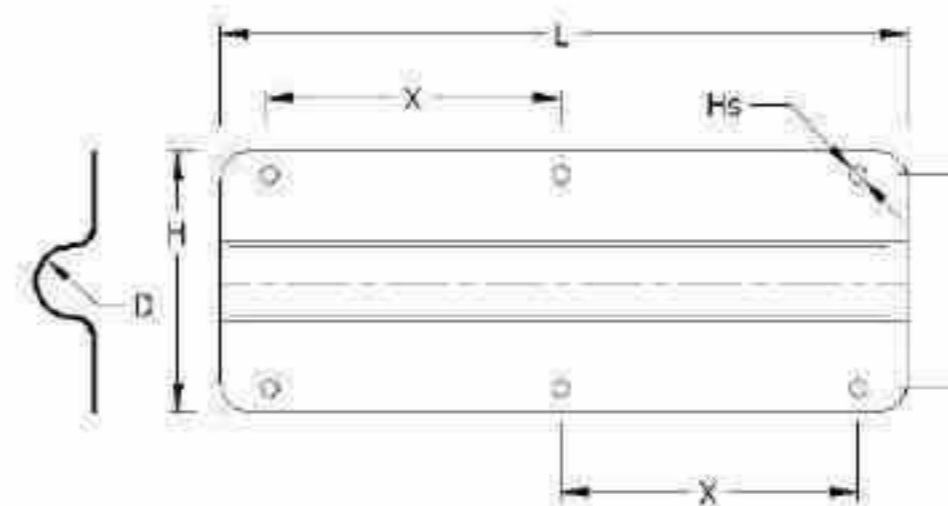

PART NUMBER	L	W	H	T	D	Hs	X	Y	KGS
233008	400	-	135	1	34	9	175	110	0.43
233037	400	-	135	1	42	9	175	110	0.45
233038	400	-	135	1	52	9	175	110	0.47

Wing Stay Tunnel Pressing

- Manufactured in 1mm Zintec steel
- Mounting pattern is 4 hole arrangement
- Finish: Zinc Spangled Galv

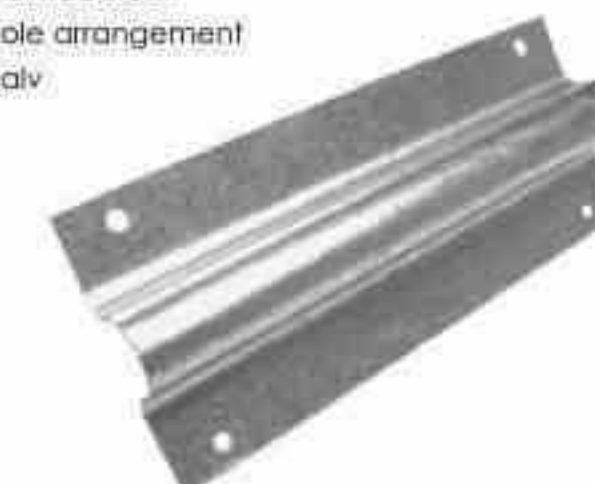
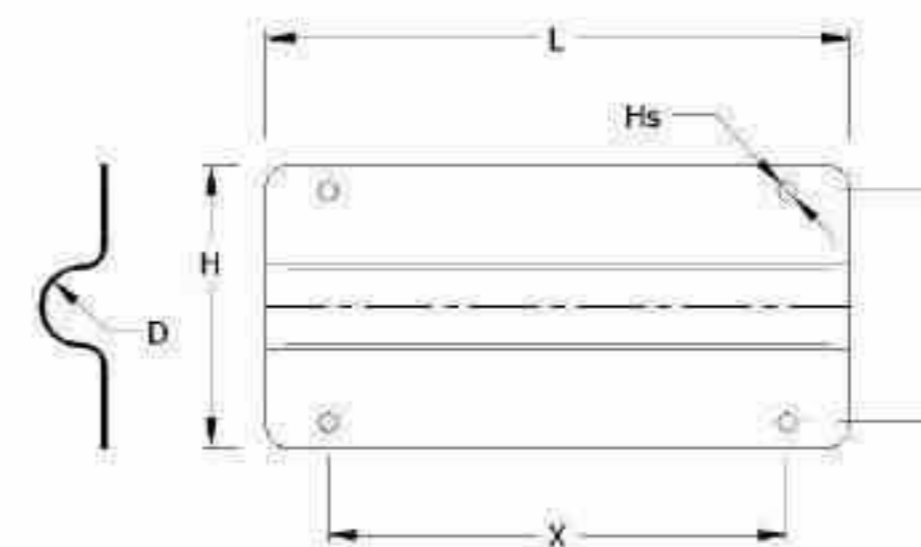

PART NUMBER	L	W	H	T	D	Hs	X	Y	KGS
233005	280	-	135	1	34	9	220	110	0.32
233034	280	-	135	1	42	9	220	110	0.35
233035	280	-	135	1	52	9	220	110	0.37

Wing Stay Backing Plate

- Manufactured in 1mm Zintec steel
- Mounting pattern is 4 or 6 hole arrangement depending upon overall length
- Finish: Zinc Spangled Galv

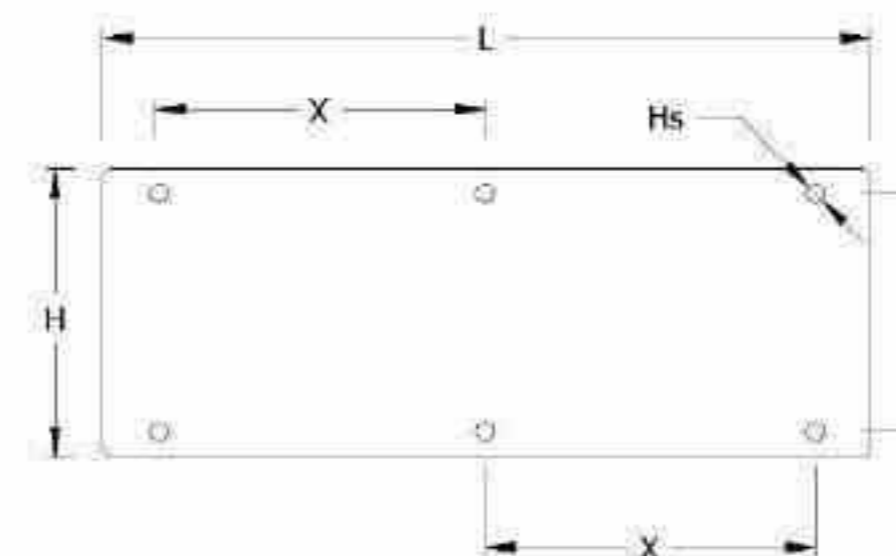

PART NUMBER	L	W	H	T	D	Hs	X	Y	KGS
233009	250	-	135	1	-	4 x 9	175	110	0.31
233010	400	-	135	1	-	6 x 9	175	110	0.33

Rubberised U-Bolt Kit

- Supplied complete with nyloc nuts and backing washers
- Finish: Plate - 1mm Zinctec U-Bolts - Zinc Plated

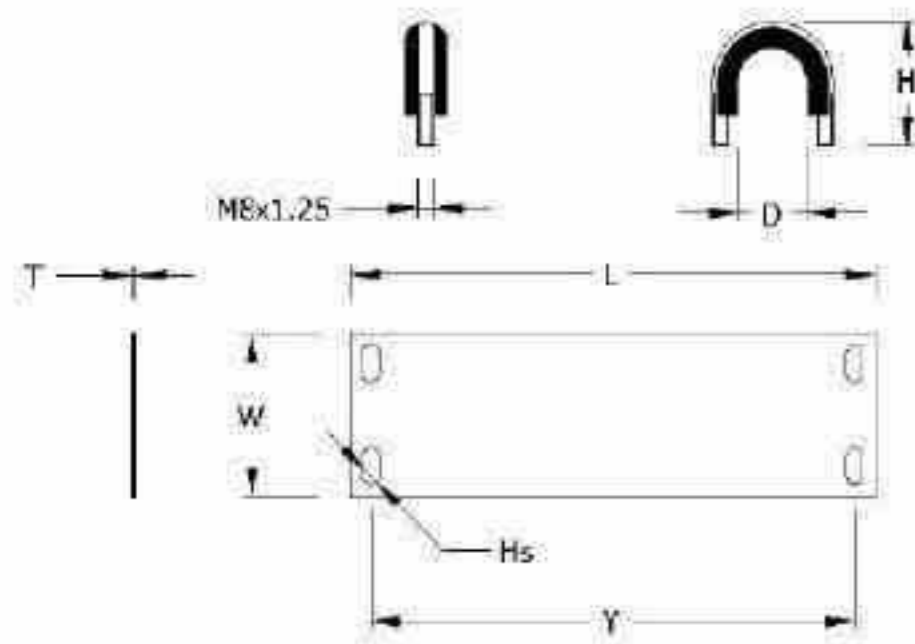

PART NUMBER	L	W	H	T	D	Hs	X	Y	KGS
233015	250	-	65	1	34	9 x 17	-	220	0.40
233094	250	-	65	1	38	9 x 17	-	220	0.40
233095	250	-	65	1	42	9 x 17	-	220	0.42
233096	250	-	65	1	50	9 x 17	-	220	0.44

Wing Stay U-Bolt Clamp

- Various sizes ranging from 34-48mm diameter
- Also supplied in axle kits with backing washers and nyloc nuts
- Finish: ZYP

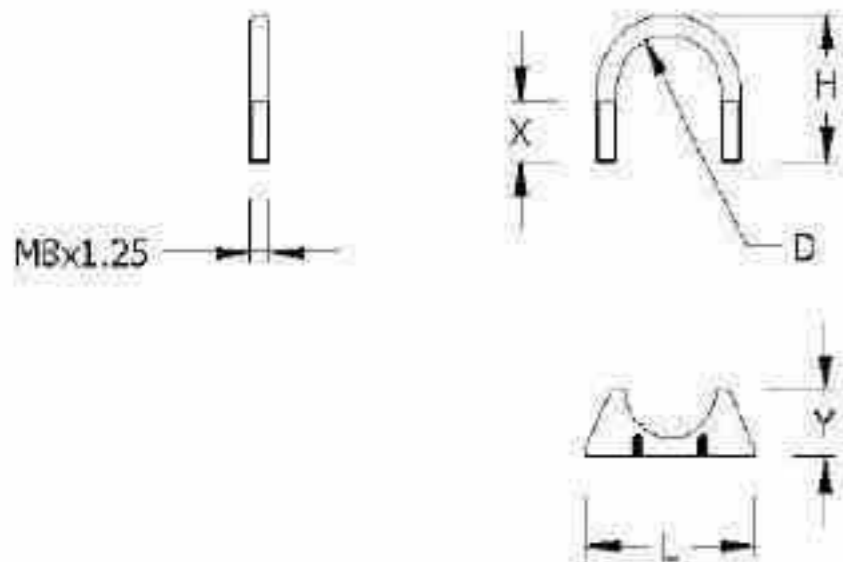

PART NUMBER	L	W	H	T	D	Hs	X	Y	KGS
233054	63	-	60	-	34	-	25	30	0.11
233055	66	-	68	-	38	-	25	30	0.12
233056	72	-	74	-	42	-	25	30	0.13
233057	78	-	78	-	48	-	25	30	0.14

Saddle Strap Long Type

- Manufactured in 3mm mild steel
- Suitable for 34mm diameter wing stays only
- Finish: Galvanised ISO 1461

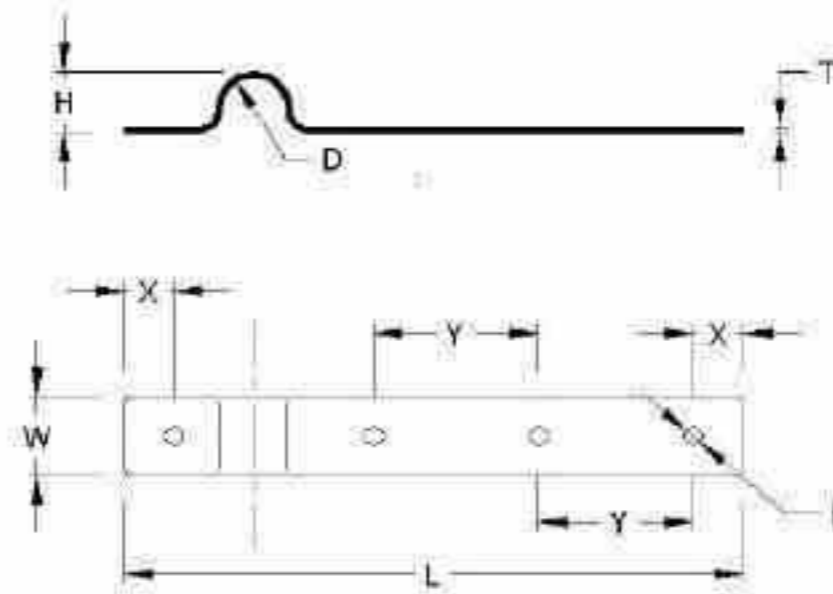

PART NUMBER	L	W	H	T	D	Hs	X	Y	KGS
233014	310	40	36	3	34	9	100	185	0.44

Saddle Strap Short Type

- Manufactured in 3mm mild steel
- Suitable for 34mm diameter wing stays only
- Finish: Galvanised ISO 1461

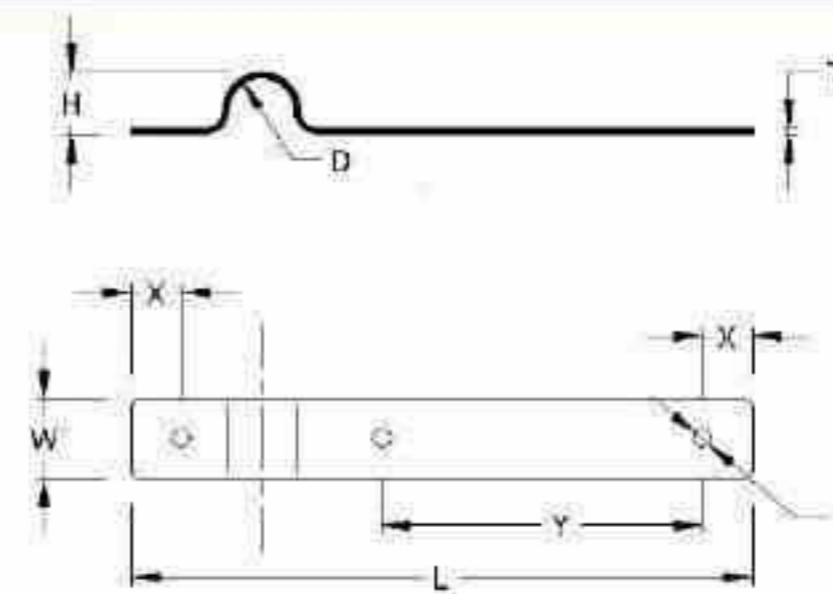

PART NUMBER	L	W	H	T	D	Hs	X	Y	KGS
233013	260	40	36	3	34	9	25	185	0.40

Anti Sill Bar

- For suppression flaps
- Sold in pairs
- Manufactured in 9mm BDMS
- Fixing kits available
- Finish: Galvanised

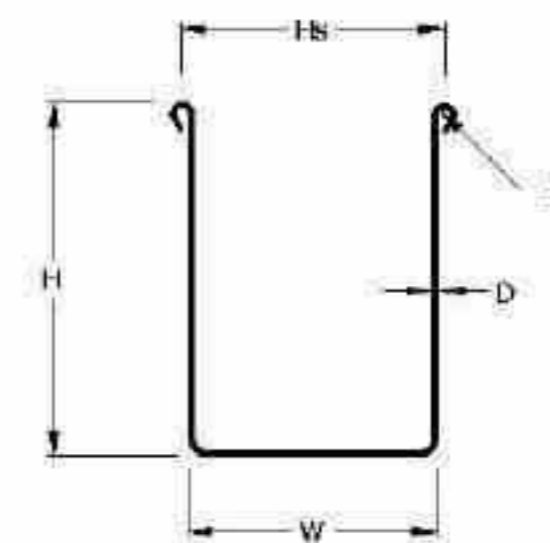

PART NUMBER	L	W	H	T	D	Hs	X	Y	KGS
233075	-	370	480	-	9	382	12	-	0.8
233076	-	370	680	-	9	382	12	-	0.9
233029	-	370	780	-	9	382	12	-	1.1
233030	-	370	870	-	9	382	12	-	1.2
233077	-	430	680	-	9	442	12	-	1.1
233078	-	430	780	-	9	442	12	-	1.3

Continental Style Wing Stay Clamp

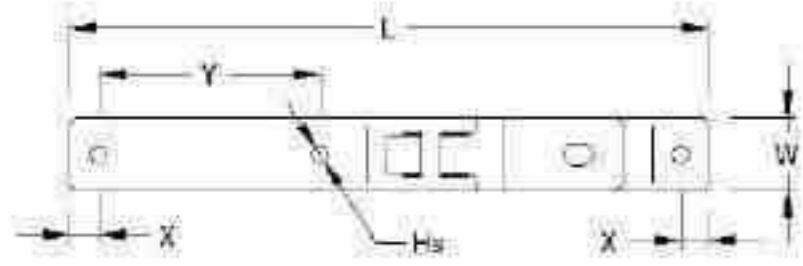

- Suitable for tube diameters between 34-42mm
- Bolt fixings supplied separately
- Finish: BZP

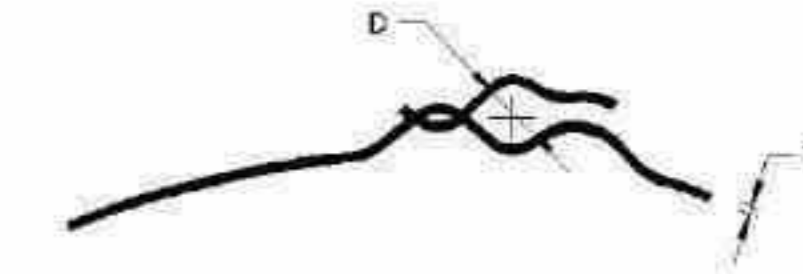

PART NUMBER	L	W	H	T	D	Hs	X	Y	KGS
233016	345	40	-	5	34 - 40	9.5	60	120	0.7

Adjustable Continental Wing Stay Clamp

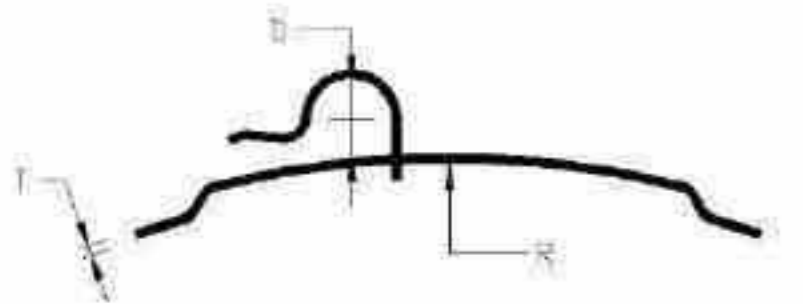

- Suitable for tube diameters between 34-50mm
- Supplied with grip fixing and rubber washers
- Finish: BZP

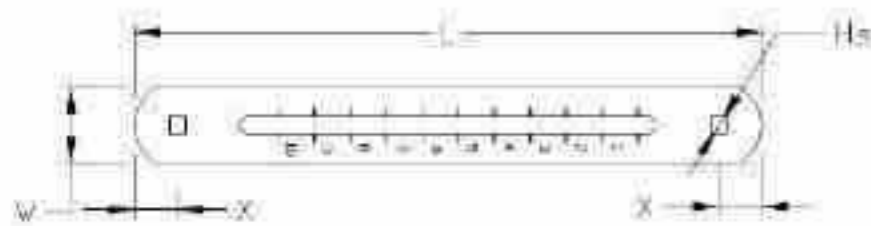

PART NUMBER	L	W	H	T	D	Hs	X	Y	KGS
233021	350	40	-	5	34	9	23	530	0.72
233109	350	40	-	5	38	9	23	530	0.72
233050	350	40	-	5	42	9	23	530	0.74
233071	350	40	-	5	50	9	23	530	0.74

Plastic Adjustable Wing Stay Clamp

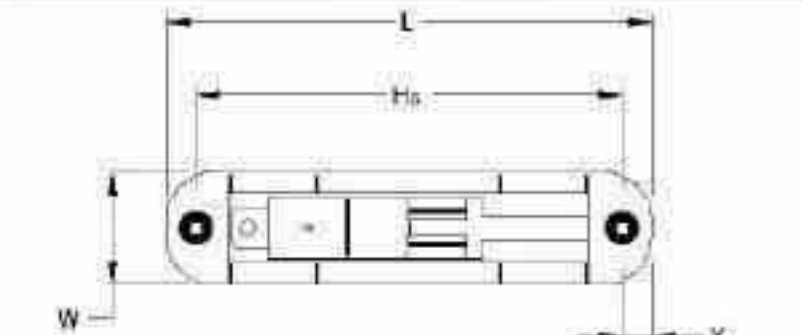

- Suitable for 34mm diameter wing stays only
- Supplied with clamp fixing only
- Finish: Black HDP

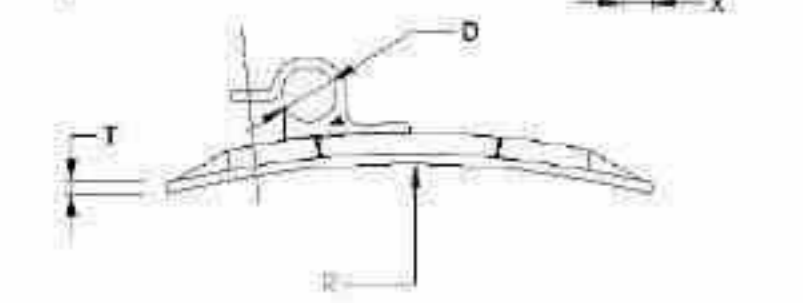

PART NUMBER	L	W	H	T	D	Hs	X	Y	KGS
233082	295	70	-	5	34	260	18	635	0.65

Kit 233025

6 hole tunnel pressing only



Wing Stay Fixing Kit

- Supplied bagged, ready for use
- Where necessary, supplied in tensile form to 8.8 grade
- Finish: Varies between BZP and ZYP - All to BS EN 12329:2000

Kit 233024

4 hole tunnel and backplate



Kit 233023

Tri-bolt wing stays - all sizes



PART NUMBER	SUITABLE FOR	REF
233023	Tri-Bolt Wing Stay	All Sizes
233024	4 Hole Tunnel Pressing Only	All Sizes
233031	4 Hole Tunnel Pressing/Backplate	All Sizes
233026	3 Hole Continental Clamp	233016
233027	4 Hole Saddle Strap	233014
233028	3 Hole Saddle Strap	233013
233025	6 Hole Tunnel Pressing Only	All Sizes
233032	6 Hole Tunnel Pressing/Backplate	All Sizes
233079	2 Hole Steel Adjustable Clamp	All Sizes
233080	2 Hole Plastic Adjustable Clamp	233082
233081	Anti Sail Bars	All Sizes

Side Mount Wheel Carrier

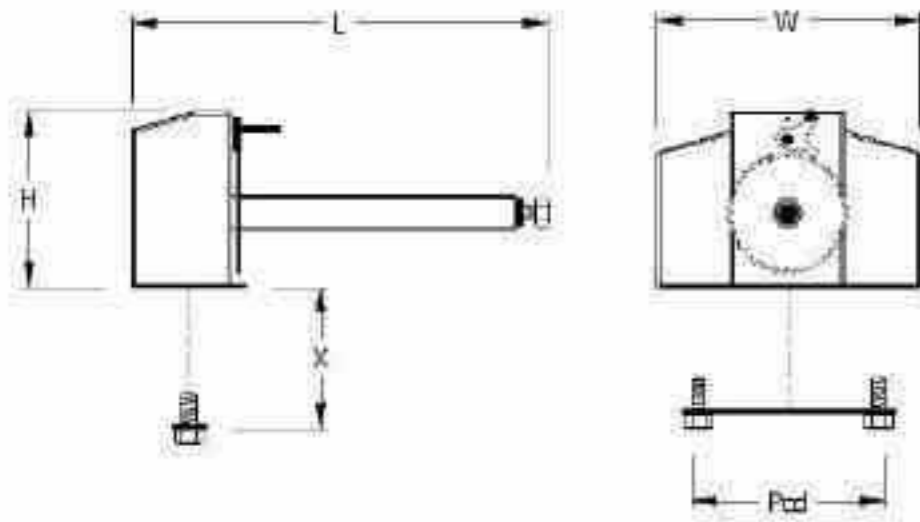

- Suitable for trucks or trailers fitted with off-set rims set on a 205mm PCD
- Finish: EPC Powder Black



PART NUMBER	L	W	H	PCD	D	Hs	X	Y	KGS
232024	430	300	200	205	-	-	1200	-	6.2

Side Mounted Wheel Carrier

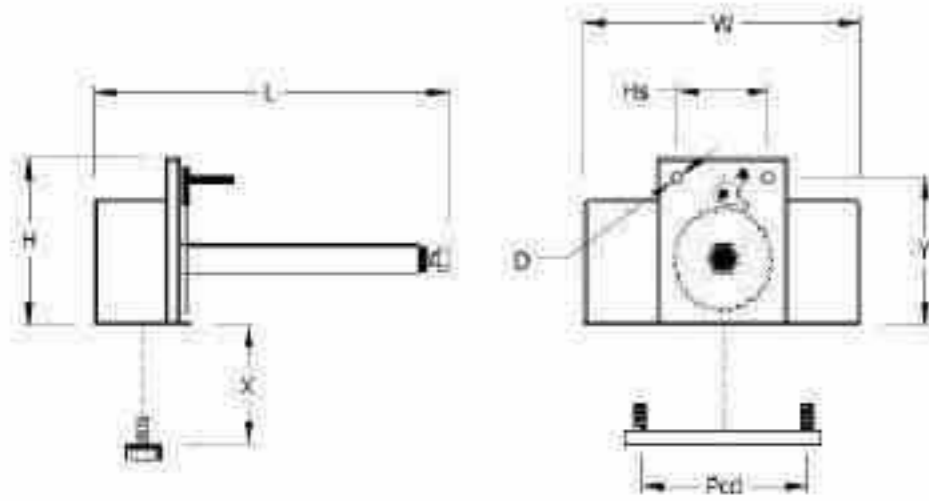

- Suitable for trucks or trailers fitted with off-set rims
- PCD range 225, 275 and 335mm
- Finish: EPC Powder Black

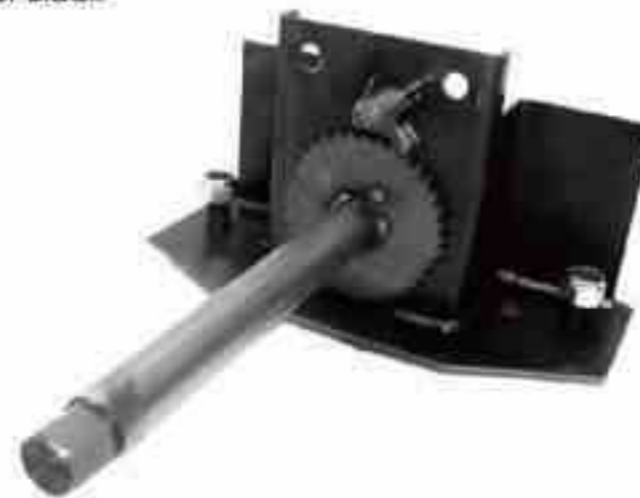

This item is an amalgamation of three separate, yet similar, carriers: 232028, 232029, 232032.

PART NUMBER	L	W	H	PCD	D	Hs	X	Y	KGS
232039	480	390	225	225-335	-	115	1200	190	11.4

'I' Beam Mounted Wheel Carrier

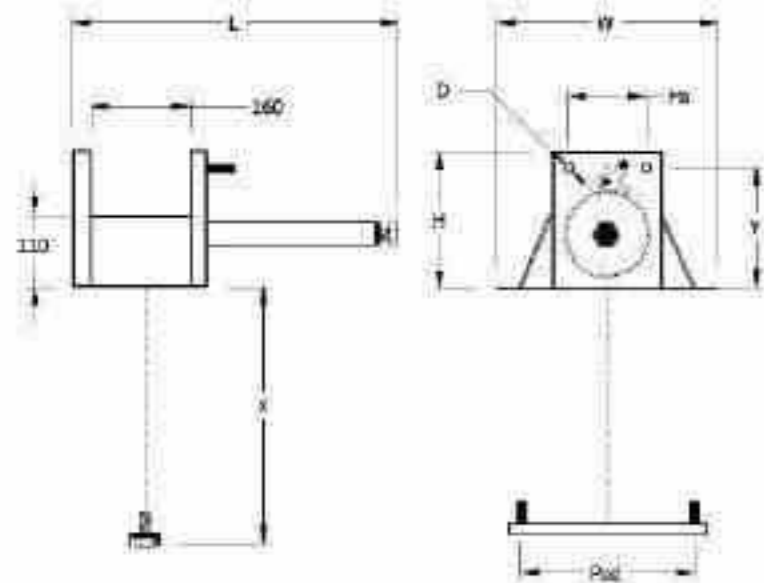

- Truck and trailer applications with off-set rims
- PCD range 225, 275 and 335mm
- Finish: EPC Powder Black



This item is an amalgamation of three separate, yet similar, carriers: 232010, 232013, 232023.

PART NUMBER	L	W	H	PCD	D	Hs	X	Y	KGS
232040	550	300	225	225-335	18.5	115	1200	190	12.0

Under Chassis Mounted Wheel Carrier

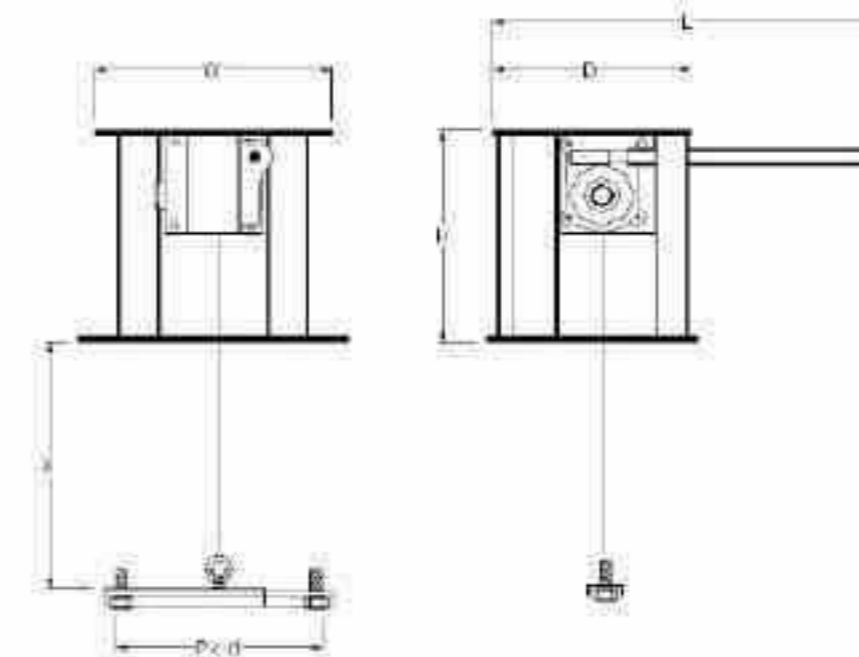

- Suitable for trailers fitted with super single wheel and tyre assemblies
- Chassis mounting by means of 4 x M12 lindaptors (supplied)
- Lifting bar has variable PCD 225-335 mm
- Finish: EPC Powder Black



PART NUMBER	L	W	H	PCD	D	Hs	X	Y	KGS
232037	580	335	280	225-335	260	-	1200	-	22.2

Side Mount Wheel Carrier

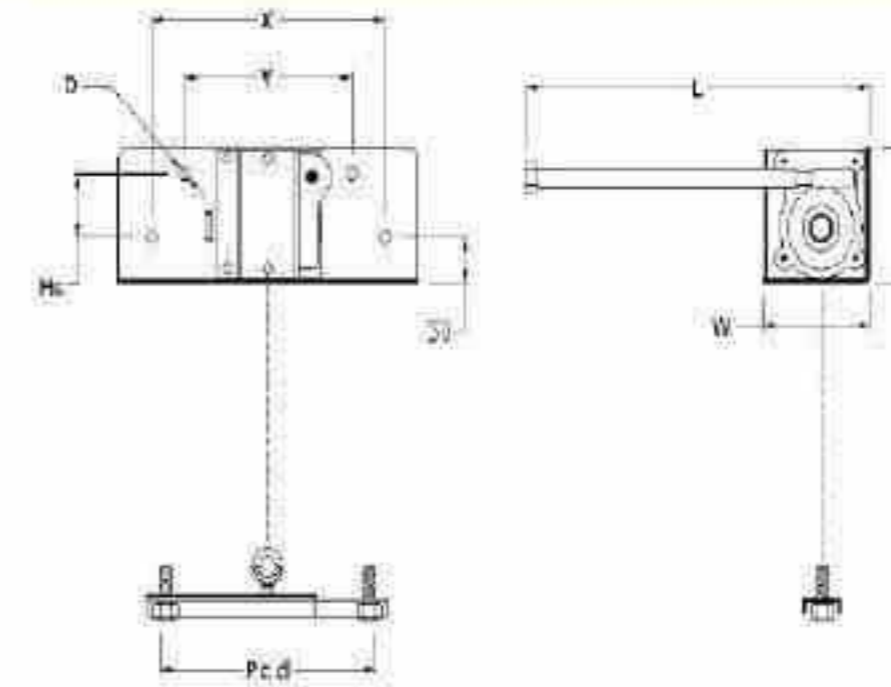

- Suitable for trucks or trailers fitted with off-set rims
- Lifting bar has variable PCD 225-335 mm
- Finish: EPC Powder Black



PART NUMBER	L	W	H	PCD	D	Hs	X	Y	KGS
232035	450	145	150	225-335	14	70	226	316	11.0

Under Chassis Mounted Wheel Carrier

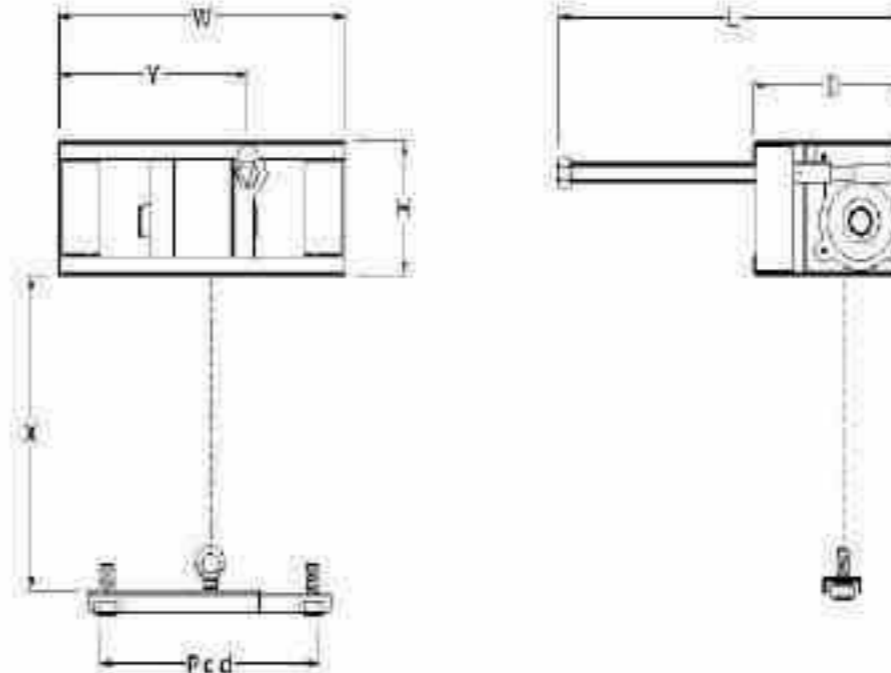

- Designed for use with vehicles fitted with wheels and tyres with an off-set rim
- Chassis mounting by means of 4 x M12 lindaptors clamped to the chassis rail (supplied)
- Lifting bar has variable PCD 225-335 mm
- Finish: EPC Powder Black



PART NUMBER	L	W	H	PCD	D	Hs	X	Y	KGS
232036	500	385	152	225-335	215	-	1200	235	13.5

Winch Handle for Spare Wheel Carrier

- Suitable for all carriers except 232024 (32 A/F)
- Finish: BZP



PART NUMBER	L	W	H	T	D	Hs	X	Y	KGS
232047	-	-	-	-	-	-	-	-	0.93

Lindaptor Fixing Kit

- Used only on carriers 232036 and 232037
- Finish: BZP / Galvanised



PART NUMBER	L	W	H	T	D	Hs	X	Y	KGS
232038	-	-	-	-	-	-	-	-	-

Lifting Bar Kit

- Suitable for all carriers except 232024
- Finish: Bar - EPC Powder Black; Cable - Galv; Nuts - BZP



PART NUMBER	L	W	H	PCD	D	Hs	X	Y	KGS
232041	-	-	-	225-335	-	-	-	-	-

Winch Cable

- Suitable for all carriers except 232024
- Old style with swaged end available for our older carrier range
- Soft eye both ends
- Finish: Galvanised



PART NUMBER	Cable Diameter (mm)	Cable Length (mm)	KGS
232042	4	1500	-

Wheel Chock

- Manufactured in steel
- Comes in three sizes; suitable for R17.5, R19.5 and R22.5 wheels
- The recommendation is that two be used on a vehicle
- Finish: Galvanised or EPC Black - please enquire

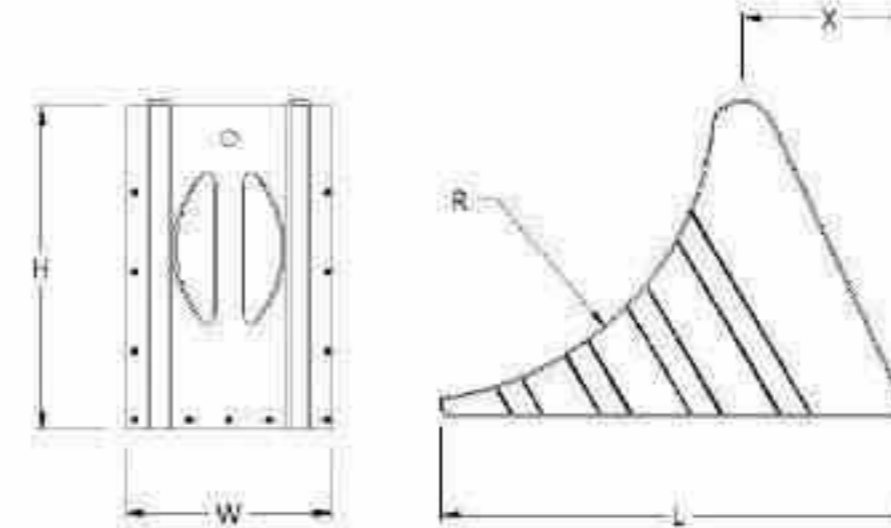

PART NUMBER	L	W	H	R	D	Hs	X	Y	KGS
232002	470	200	230	560	-	-	150	-	4.3
232003	380	160	190	460	-	-	120	-	2.8
232004	320	120	150	360	-	-	100	-	1.0

Wheel Chock Holder

- Manufactured in steel
- Suitable for use with steel wheel chocks
- Mounting holes are 9mm diameter
- Finish: Galvanised or EPC Black

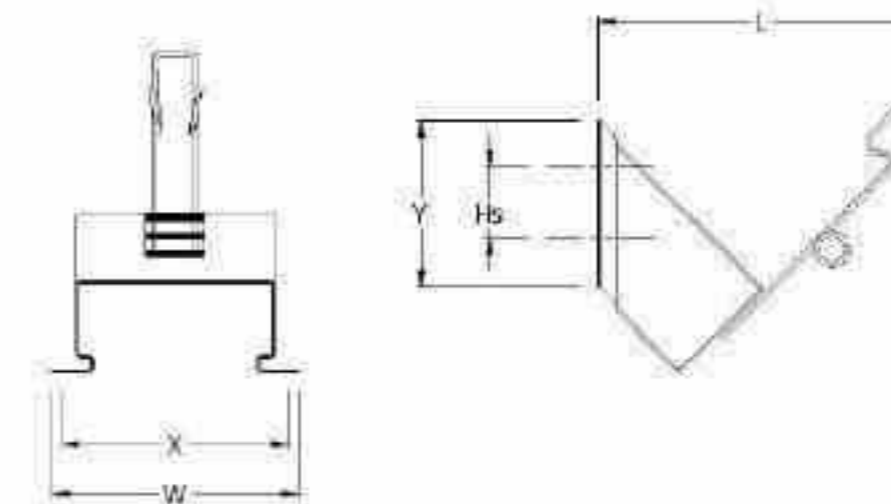

PART NUMBER	L	W	H	R	D	Hs	X	Y	KGS
232005	258	246	-	-	9	80	226	155	1.30
232006	225	207	-	-	9	60	186	123	0.85
232007	225	164	-	-	9	40	144	92	0.55

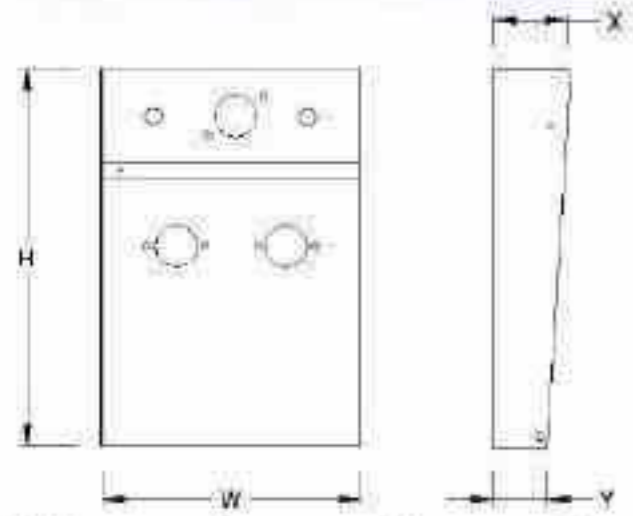

High-Mount 2 Line Coupling Box

- Manufactured in 2mm thick steel
- Features 24n-24s and ISO 7638 ABS-EBS cut-outs
- Hinged panel plate with check chain
- Finish: Zinc Plated



PART NUMBER	L	W	H	T	D	Hs	X	Y	KGS
231046	-	305	450	-	-	-	120	80	6.2

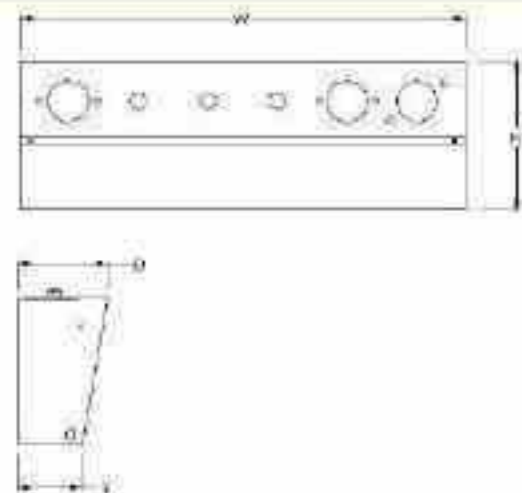

Slim-Line 3 Line Coupling Box

- Manufactured in 2mm thick steel
- Features 24n-24s and ISO 7638 ABS-EBS cut-outs
- Hinged front panel plate with check chain
- Finish: Zinc Plated



PART NUMBER	L	W	H	T	D	Hs	X	Y	KGS
231019	-	604	200	-	120	-	-	85	5.5

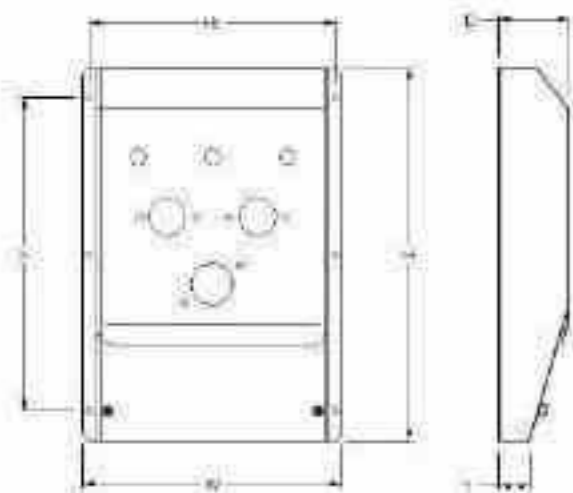

High-Mount 3 Line Coupling Box

- Manufactured in 2mm thick steel
- Features 24n-24s and ISO 7638 ABS-EBS cut-outs
- Lower removable cable entry cover
- Finish: Zinc Plated



PART NUMBER	L	W	H	T	D	Hs	X	Y	KGS
231001	-	345	500	-	90	329	420	40	4.3

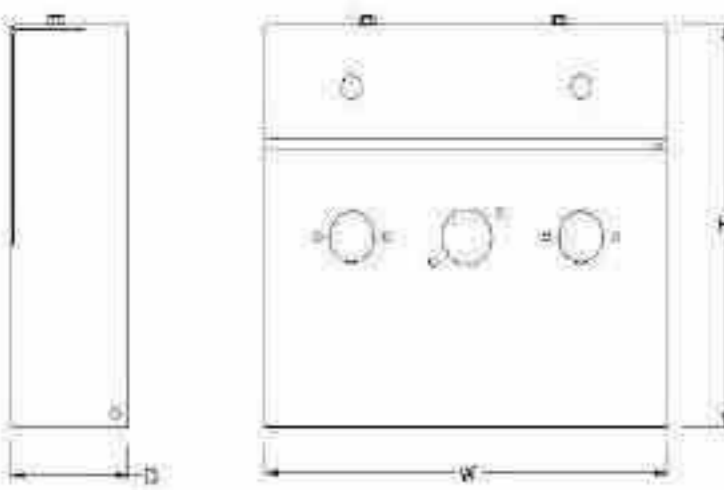

Mid-Mount 2 Line Coupling Box

- Manufactured in 2mm thick steel
- Features 24n-24s and ISO 7638 ABS-EBS cut-outs
- Hinged panel plate with check chain
- Finish: Zinc Plated



PART NUMBER	L	W	H	T	D	Hs	X	Y	KGS
231025	-	450	390	-	130	-	-	-	7.2

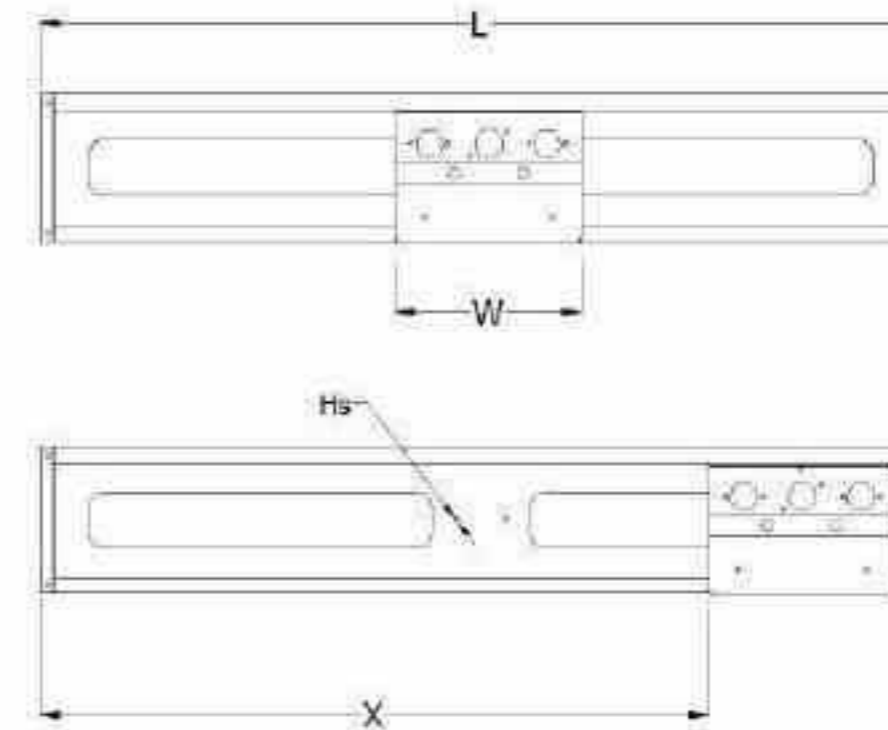

Rolling Coupling Box

- Manufactured in 403 stainless all baited construction
- Supplied complete with industry standard energy chain for electrical and pneumatic services
- Standard configuration is for 24N-24S ABS/EBS plus 'C' couplings
- Cable guard to rear of panel front is standard
- Unique roller arrangement ensures continuous free rolling of the service panel and reduces coil stress
- Attachment by means of universal fixing holes pierced in the rear face of the body section
- Non-standard applications available and supplied to customers requirements

UNI-TRAK

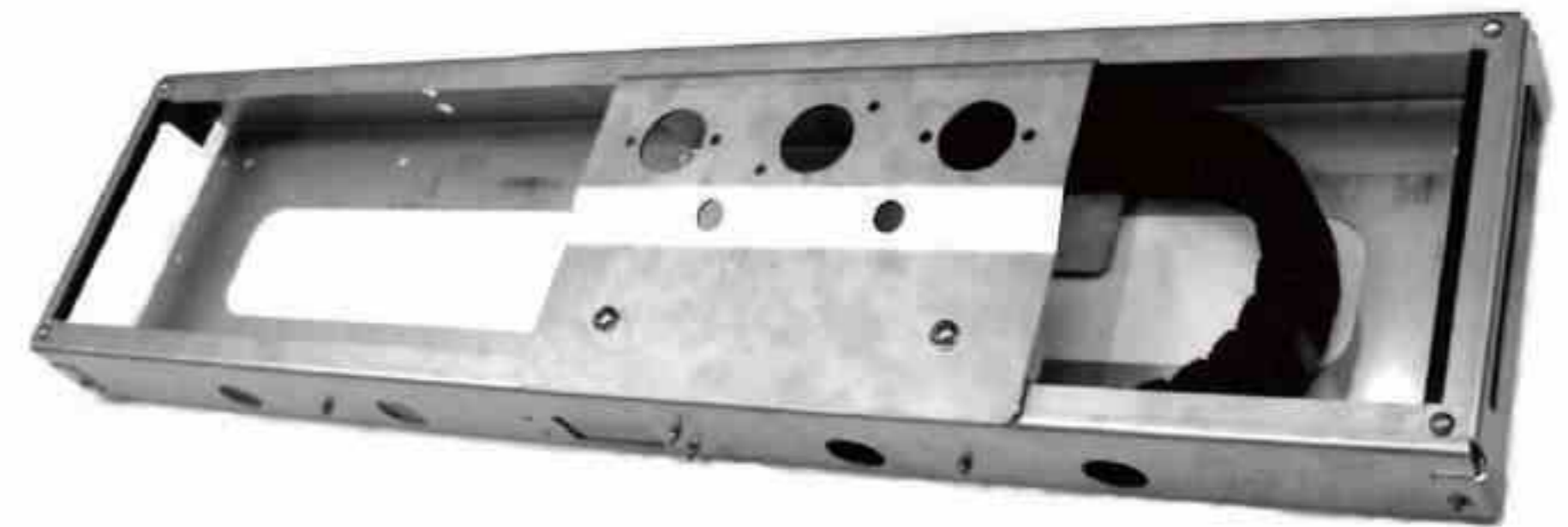

PART NUMBER	L	W	H	DEPTH	X	Hs	KGS
231011	1720	380	288	95	1350	9.5	19.5
231012	1820	380	288	95	1450	9.5	21.5
231013	1220	380	288	95	750	9.5	15.5
231014	2320	380	288	95	-	9.5	-
231015	2120	380	288	95	155	9.5	22.9
231016	1920	380	288	95	-	9.5	-

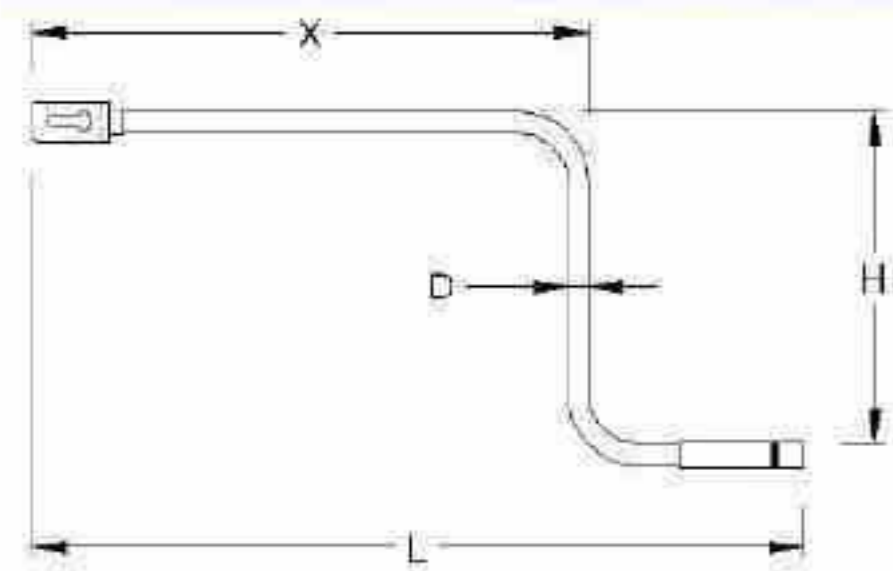

Winding Handle

- Manufactured in ERW tube or BDMS bar
- Design specs:
 - 238010 - Tubular slotted end
 - 238011 - Solid slotted end
 - 238012 - Solid hexagon end 32 A/F
- Finish: EPC Powder Black



PART NUMBER	L	W	H	T	D	Hs	X	Y	KGS
238010	790	-	350	-	32	-	530	-	2.6
238011	840	-	350	-	22	-	560	-	4.0
238012	820	-	350	-	22	-	540	-	3.5

Hexagon Extension

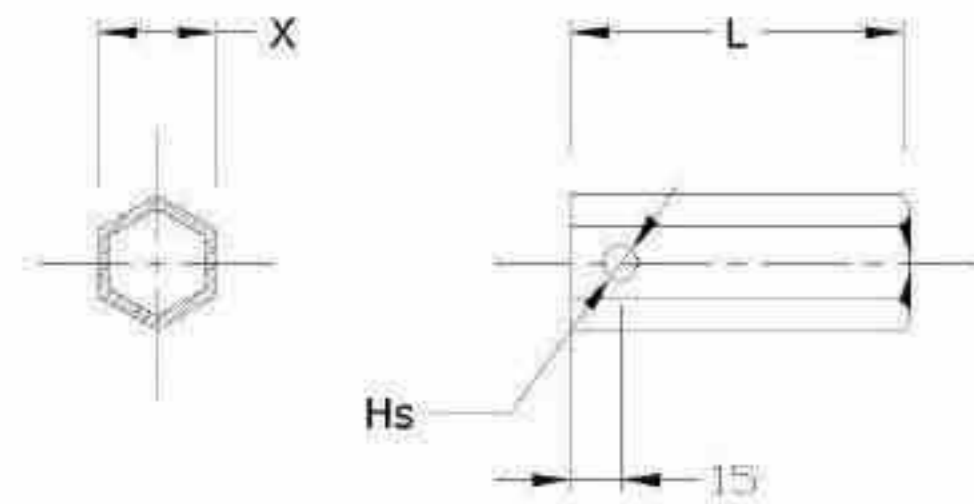

- Machined from solid hex bar
- Finish: Zinc Plated



PART NUMBER	L	W	H	T	D	Hs	X	Y	KGS
238013	70	-	-	-	-	11	32	-	0.3
238014	102	-	-	-	-	11	32	-	0.4
238015	280	-	-	-	-	11	32	-	1.8

Axle Shaft

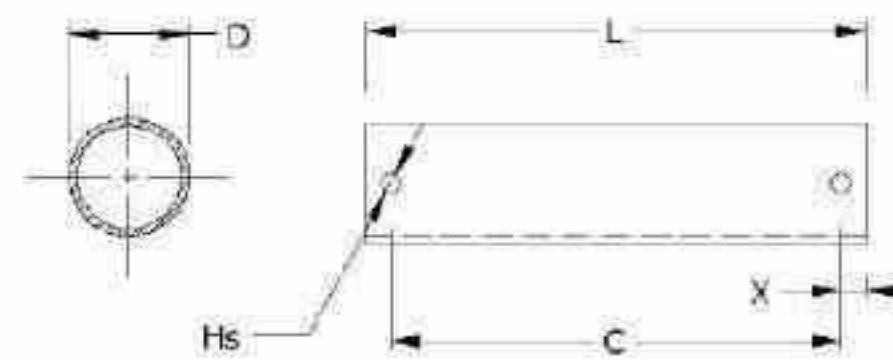

- Manufactured in ERW tube or BDMS bar
- Supplied with a split or cotter pin, depending on version specified
- Finish: EPC Powder Black



PART NUMBER	L	W	H	T	D	Hs	X	Y	KGS
238009	200	180	-	-	43	6	10	-	0.8
238007	200	180	-	-	49	6	10	-	0.9
238003	385	365	-	-	49	10	10	-	1.5

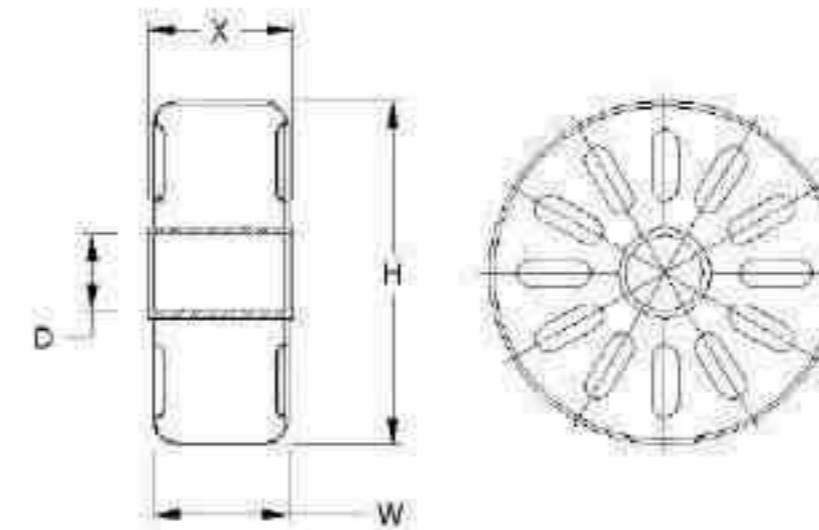

Landing Wheel

- Both 51mm and 44mm options
- Available for UK and European use
- Finish: EPC Powder Black



PART NUMBER	OPTION	L	W	H	T	D	Hs	X	Y	KGS
238004	UK	-	90	230	-	51	-	102	-	4.7
238005	EURO	-	90	230	-	44	11	102	-	4.7

Rocking Foot

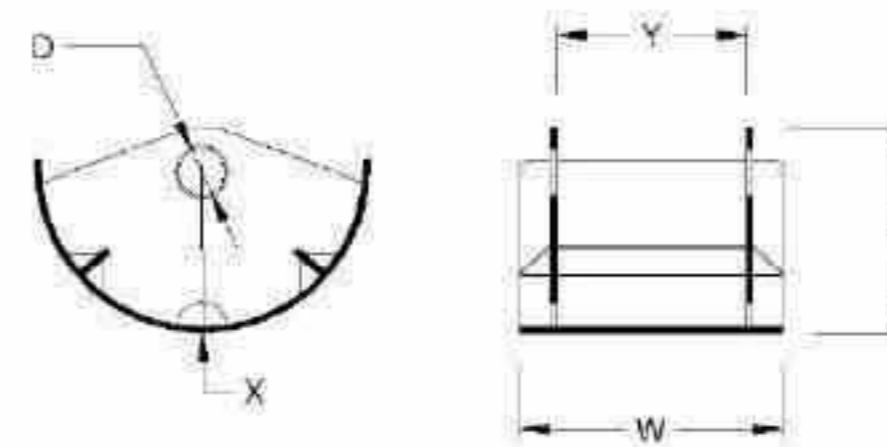

- UK 51mm and European 44mm axle options available
- Finish: EPC Powder Black



PART NUMBER	OPTION	L	W	H	T	D	Hs	X	Y	KGS
238000	UK	-	220	175	-	51	-	132	154	8.2
238001	EURO	-	220	175	-	44	-	132	154	8.2

Flat Foot

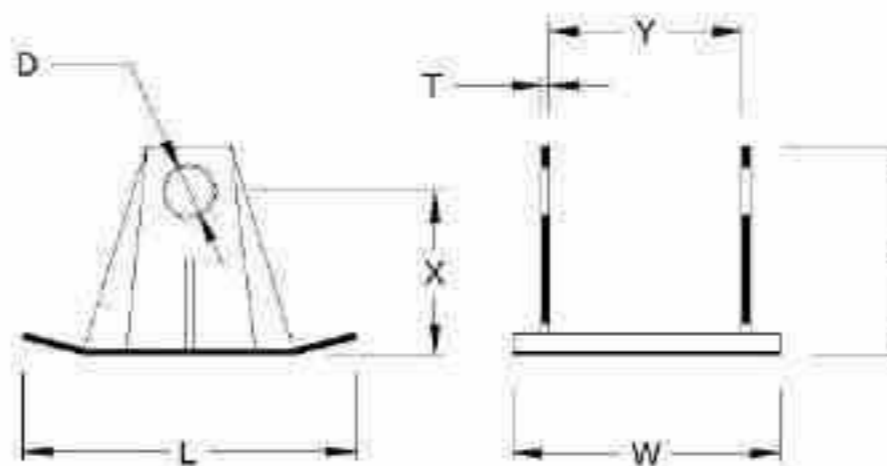

- UK 51mm and European 44mm axle options available
- Finish: EPC Powder Black



PART NUMBER	OPTION	L	W	H	T	D	Hs	X	Y	KGS
238002	UK	300	254	152	-	51	-	112	154	6.0
238006	EURO	300	254	152	-	44	-	112	154	6.0

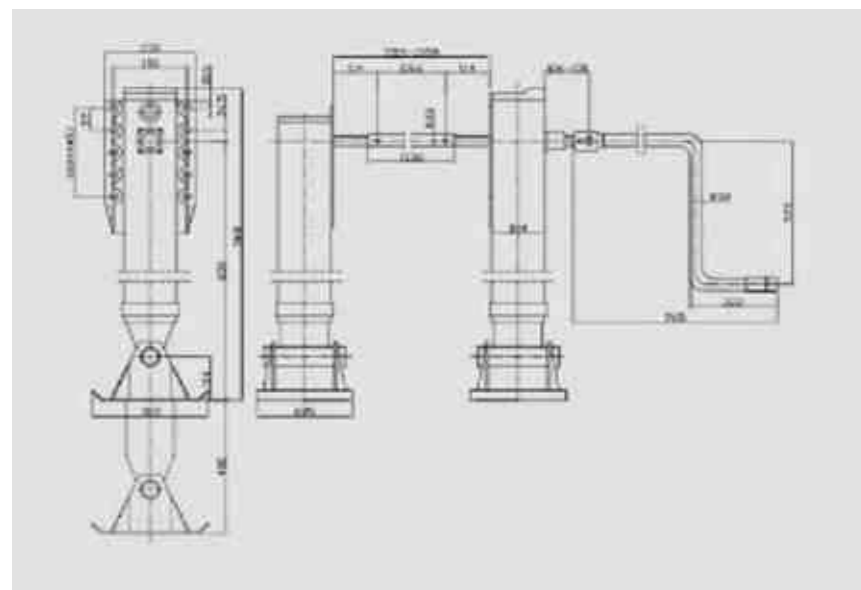

JLCL28000A SERIES LANDING GEAR

- Gearbox inside, double speed designed.
- Lead screw is rolled forming with extra-duty feature steel.
- Quality grease can bear hot and cold condition.
- Surface powder coating, delicate, Water-proof and Rust-proof.
- Static load, lift test and drop test accord with ABS.



MODEL	STATIC LOAD CAPACITY (T)	LIFING CAPACITY (T)	HIGH GEAR (mm)	LOW GEAR (mm)	TRAVEL MAX (mm)	HEIGHT (mm)	CRANK FORCE (KG)	WEIGHT (KG)
JLCL25000A	70	25	7.5	0.84	17" / 19"	780 / 830	25	98
JLCL28000A	80	28	7.5	0.84	17" / 19"	780 / 830	25	100
JLCL30000A	80	30	7.5	0.84	17" / 19"	780 / 830	25	102

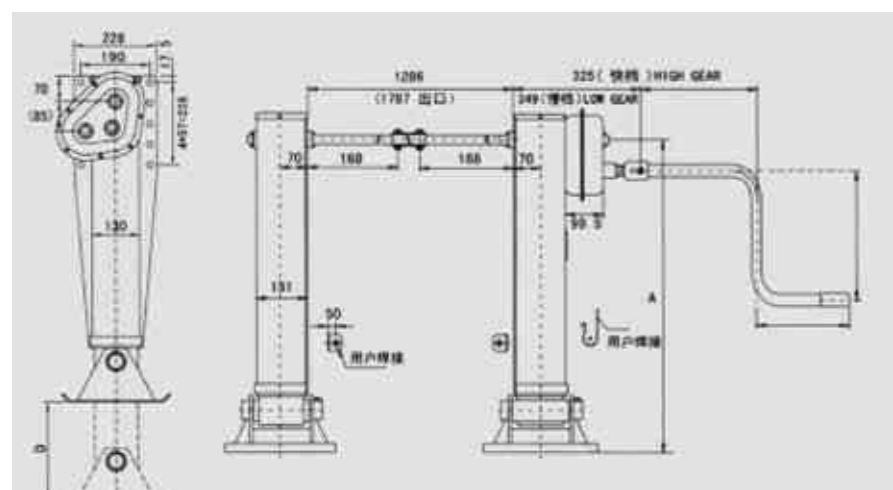

JLCL28000B SERIES LANDING GEAR

- Gearbox outside, double speed designed.
- Quality grease can bear hot and cold condition.
- Surface powder coating, delicate, rust-proof.
- Multi-type shoes available for different requirement.



MODEL	STATIC LOAD CAPACITY (T)	LIFING CAPACITY (T)	HIGH GEAR (mm)	LOW GEAR (mm)	TRAVEL MAX (mm)	HEIGHT (mm)	CRANK FORCE (KG)	WEIGHT (KG)
JLCL25000B	72	25	5.42	0.72	17" / 19"	792 / 842	25	100
JLCL28000B	80	28	5.42	0.72	17" / 19"	792 / 842	25	103
JLCL30000B	80	30	5.42	0.72	17" / 19"	792 / 842	25	105

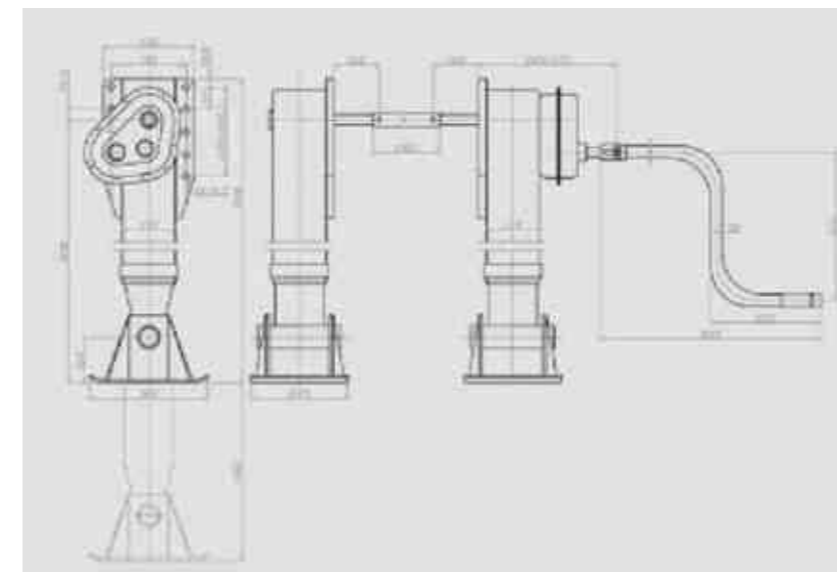

JLCL28000C SERIES LANDING GEAR

- Double speed designed.
- Lead screw is rolled forming with extra-duty feature steel.
- Quality grease can bear hot and cold condition.
- Gears are quality forging instead of weak casting.
- Surface powder coating, delicate, Water-proof and Rust-proof.
- Quality control system guarantee best quality.
- Static load, lift test and drop test accord with ABS specification



MODEL	STATIC LOAD CAPACITY (T)	LIFING CAPACITY (T)	HIGH GEAR (mm)	LOW GEAR (mm)	TRAVEL MAX (mm)	HEIGHT (mm)	CRANK FORCE (KG)	WEIGHT (KG)
JLCL25000C	70	25	5.42	0.72	17" / 19"	780 / 830	25	98
JLCL28000C	80	28	5.42	0.72	17" / 19"	780 / 830	25	100
JLCL30000C	80	30	5.42	0.72	17" / 19"	780 / 830	25	102

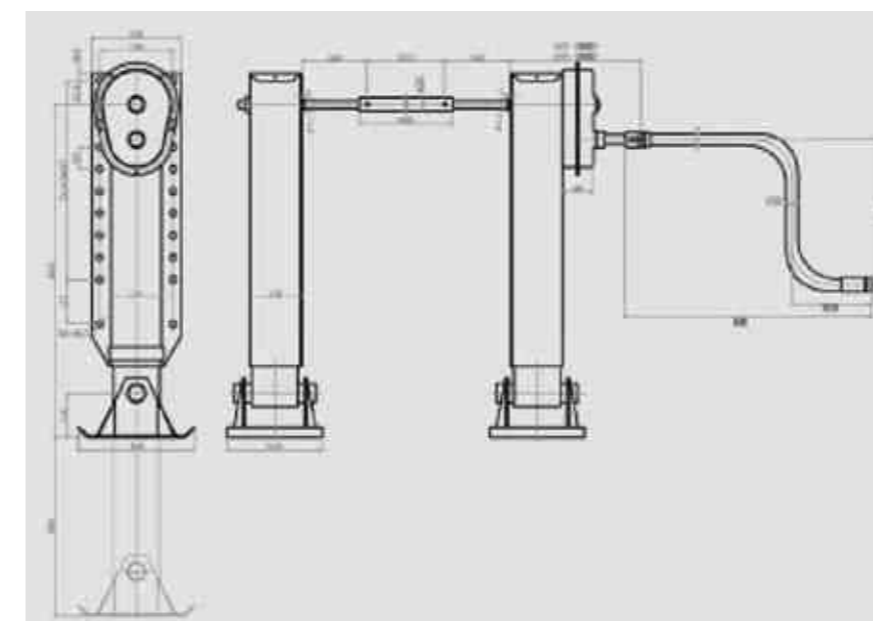

JLCL28000F SERIES LANDING GEAR

- Double speed designed.
- Lead screw is rolled forming with extra-duty feature steel.
- Quality grease can bear hot and cold condition.
- Gears are quality forging instead of weak casting.
- Surface powder coating, delicate, Water-proof and Rust-proof.
- Quality control system guarantee best quality.
- Static load, lift test and drop test accord with ABS Specification.



MODEL	STATIC LOAD CAPACITY (T)	LIFING CAPACITY (T)	HIGH GEAR (mm)	LOW GEAR (mm)	TRAVEL MAX (mm)	HEIGHT (mm)	CRANK FORCE (KG)	WEIGHT (KG)
JLCL25000F	80	25	10.8	0.8	17" / 19"	810 / 860	35	100
JLCL28000F	80	28	10.8	0.8	17" / 19"	810 / 860	35	102
JLCL30000F	80	30	10.8	0.8	17" / 19"	810 / 860	35	105

OTHER SERIES LANDING GEAR FOR DIFFERENT MARKETS NEED



SPARE PARTS SERIES FOR LANDING GEAR

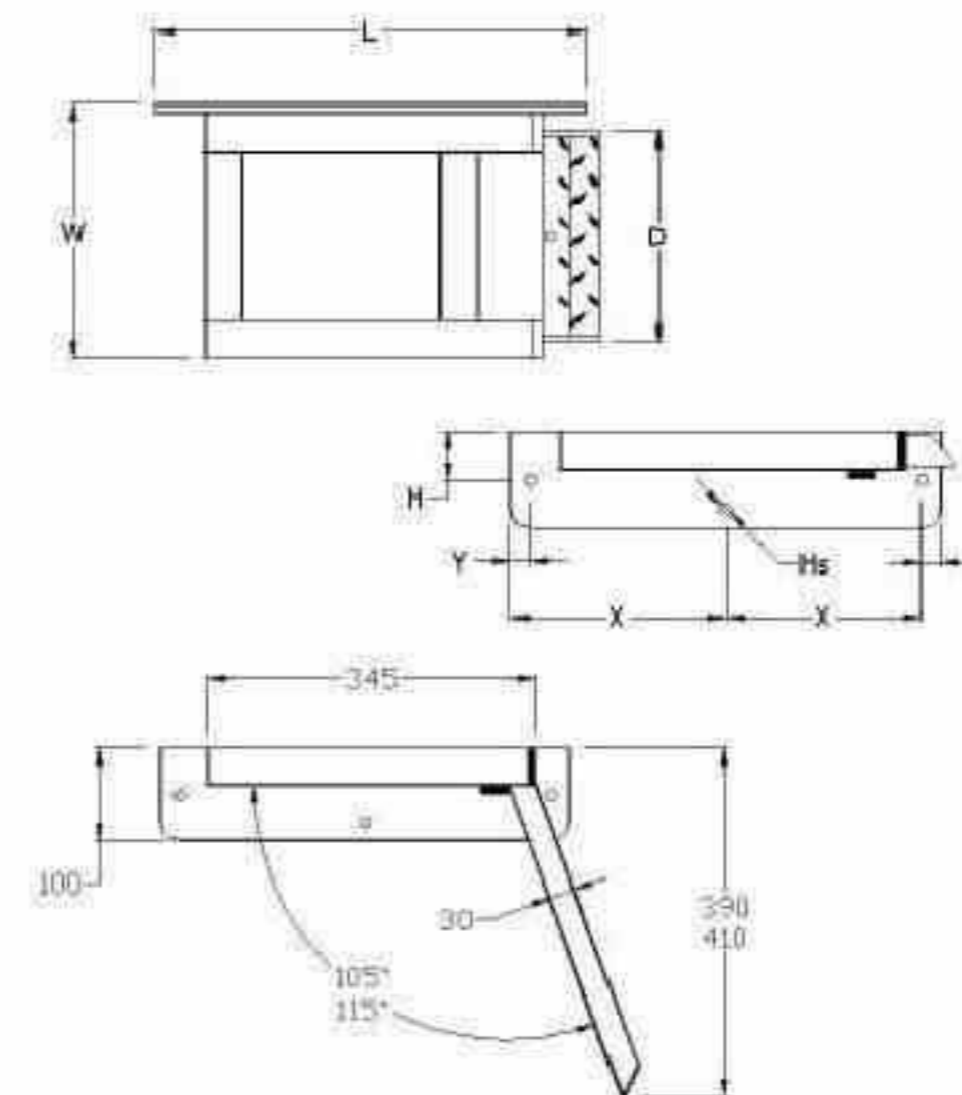

Tail Lift Tuck-Away Step

- Bolts directly onto under body tail lift framework
- Attached by means of 3 x 11mm holes
- Finish: Galvanised ISO1461



PART NUMBER	L	W	H	T	D	Hs	X	Y	KGS
237003G	345	260	50	-	215	11	200	20	8.7

Flat Bar Hooped Step

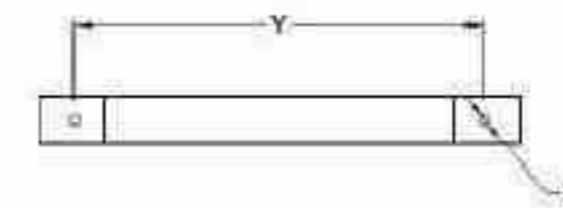

- Formed in 10mm flat strip
- This step is designed to attach to the underside of the vehicle chassis
- Under body fixing by means of 2 x 11mm holes
- Finish: Galvanised ISO1461

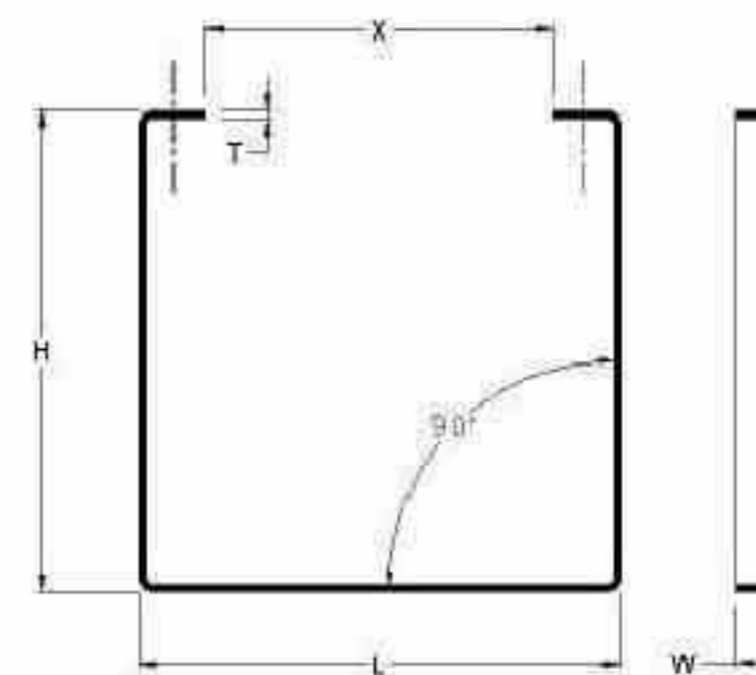

PART NUMBER	L	W	H	T	D	Hs	X	Y	KGS
237002	500	50	375	8	-	11	360	424	3.25

2 Rung Pull-Out Step

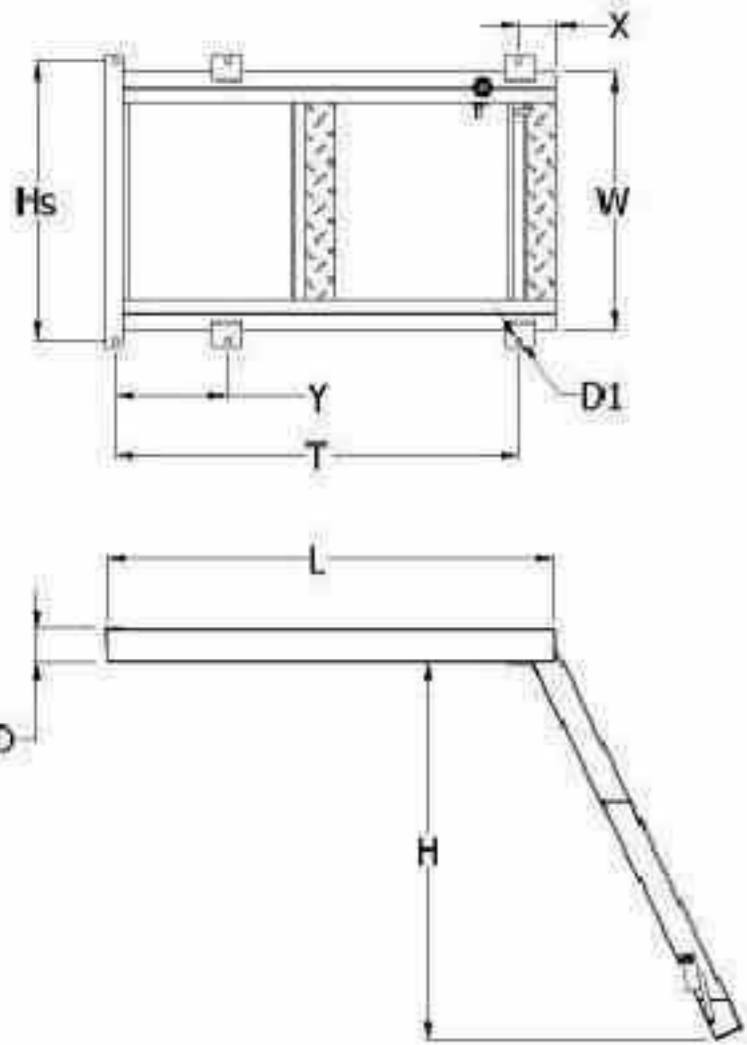

- Manufactured in steel
- Chequer plate treads
- Unique transit latch for secure stowage
- Under body fixing by means of 5 x 11mm holes
- Finish: Galvanised ISO1461



PART NUMBER	L	W	H	T	D	D1	Hs	X	Y	KGS
237016G	600	355	515	545	45	10*15	390-400	50	185	6.6

3 Rung Pull-Out Step

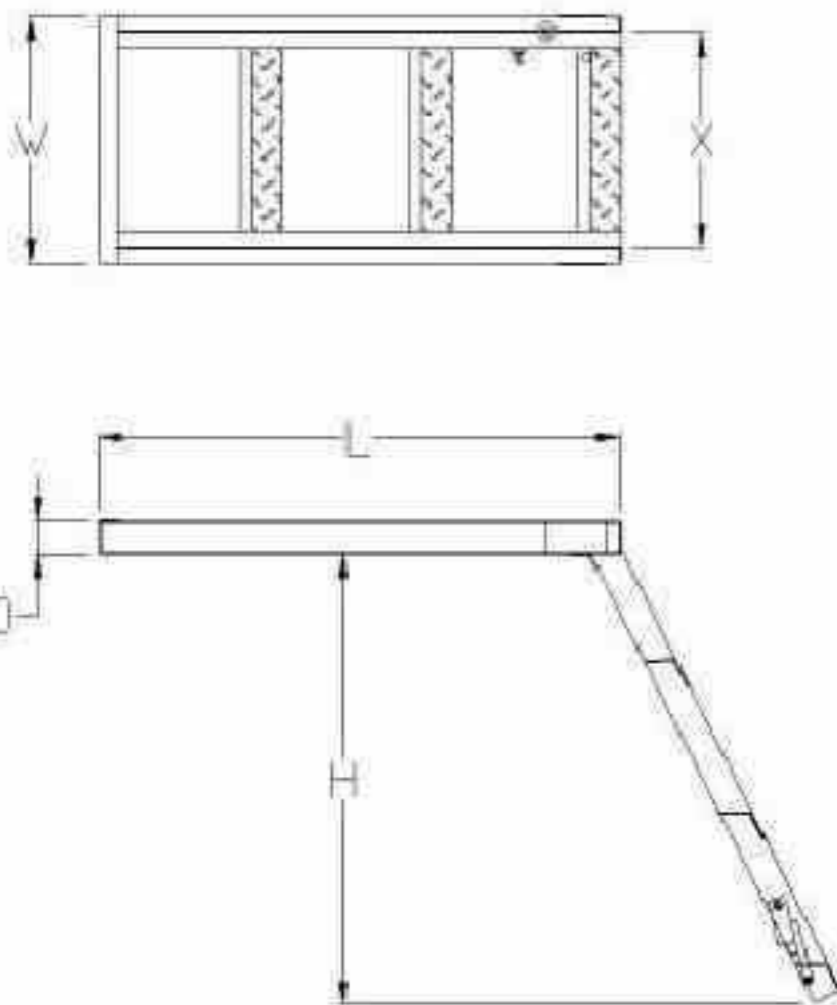

- Manufactured in steel
- Chequer plate treads
- Unique transit latch for secure stowage
- Under body fixing by means of welding to vehicles chassis
- Finish: Galvanised ISO1461



PART NUMBER	L	W	H	T	D	Hs	X	Y	KGS
237039G	700	330	600	-	45	-	280	-	6.6

2 Rung Reefer Step

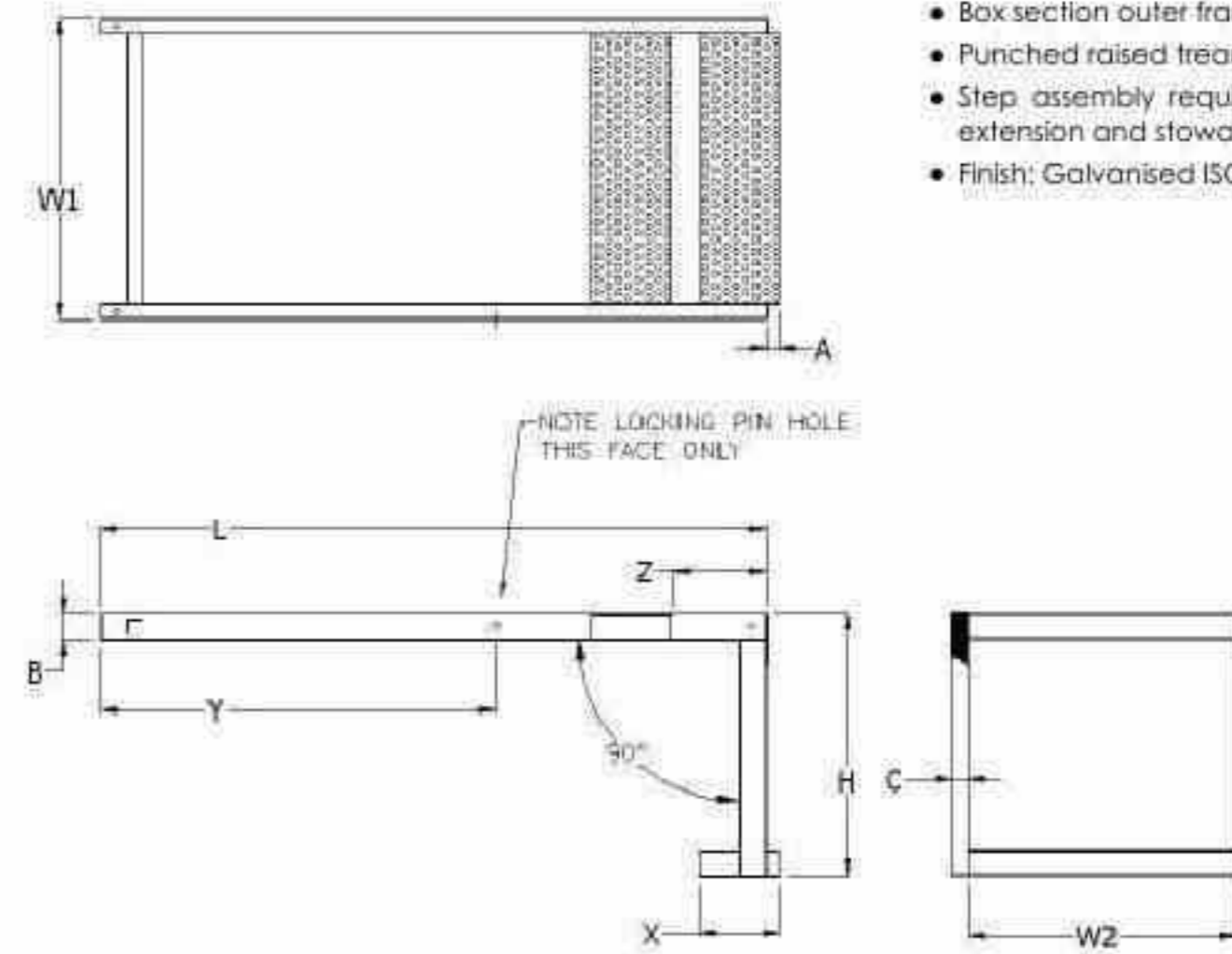

- Box section outer frame
- Punched raised tread plates
- Step assembly requires steel fabricated outer frame for extension and stowage (not supplied)
- Finish: Galvanised ISO1461



PART NUMBER	L	W1	W2	A	B	C	H	X	Y	Z	KGS
237008	1240	500	560	25	50	30	490	155	735	175	17

3 Rung Pull-out Platform Step

- All steel construction
- Chequer platform and ladder treads
- Unique transit latch for secure stowage
- Under chassis fixing by means of 4 x M10 bolts min 8.8 grade (not supplied)
- Design working load 120kgs
- Finish: Galvanised ISO1461

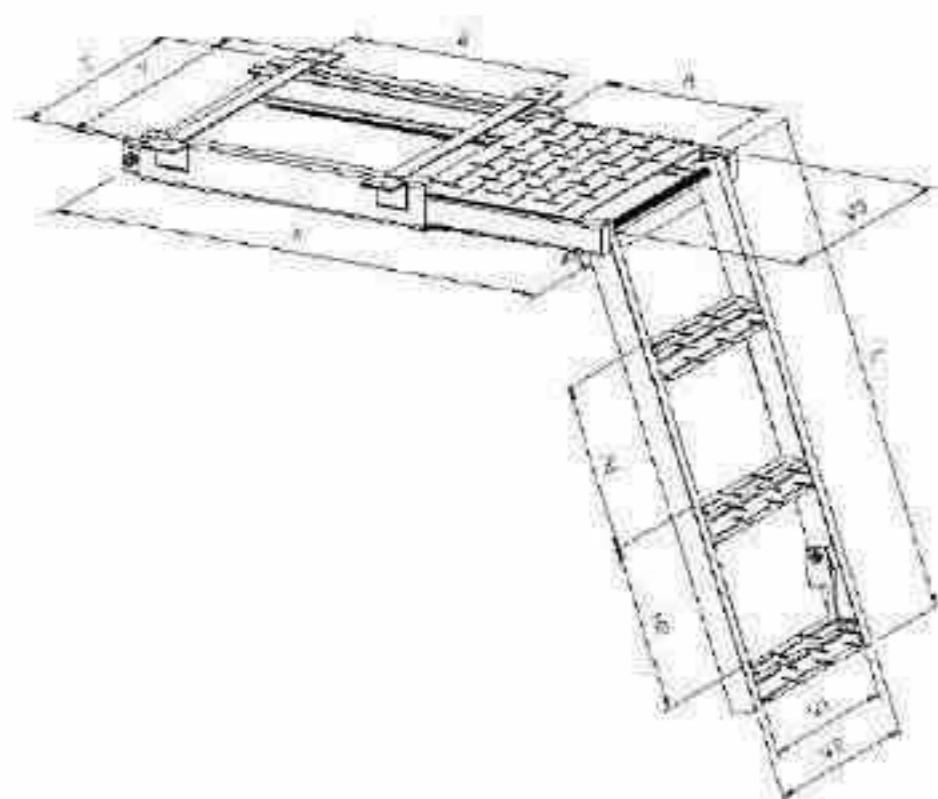

PART NUMBER	L	W1	W2	W3	H1	H2	A	B	X	Y	Z	KGS
237045G	800	268	284	330	280	280	220	330	825	395	288	16

2 Rung Pull-out Platform Step

- All steel construction
- Chequer platform and ladder treads
- Unique transit latch for secure stowage
- Under chassis fixing by means of 4 x M10 bolts min 8.8 grade (not supplied)
- Design working load 137.5kgs
- Safe working load 110kgs
- Finish: Galvanised ISO1461

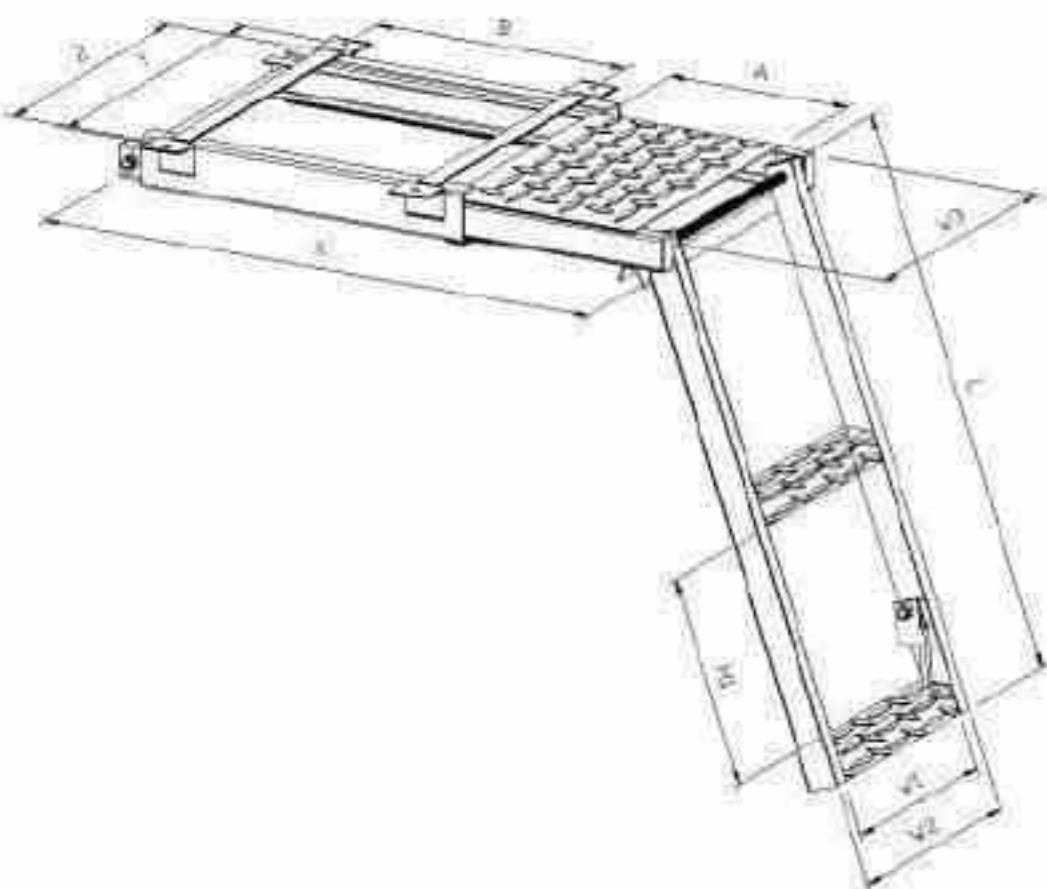

PART NUMBER	L	W1	W2	W3	H1	H2	A	B	X	Y	Z	KGS
237005G	600	268	284	340	300	-	250	230	810	390	-	11.3

2E-4

Tel: 86-574-82815295/82815296
Web: jilonghardware.com

Fax: 86-574-82815296
E-mail: sales@jilonghardware.com

Folding step

- All steel construction
- Honeycomb self cleaning treads
- Over-centre folding action for secure storage
- Choice of outer frame construction:
 - 237050G - Angle frame
 - 237051G - RHS
- Under chassis fixing by means of 4 x M10 bolts min 8.8 grade (not supplied)
- Design working load 140kgs
- Finish: Galvanised ISO1461

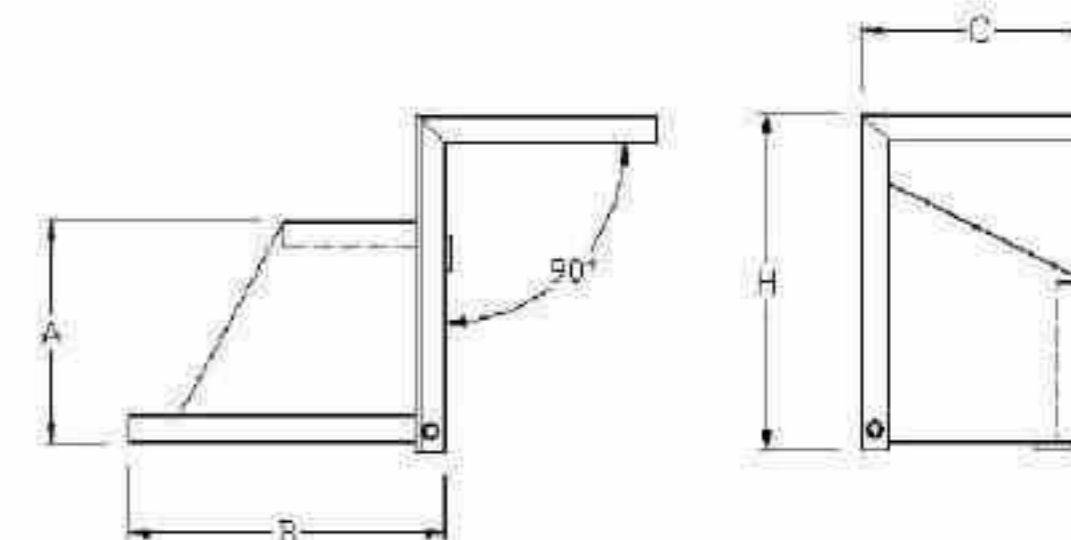
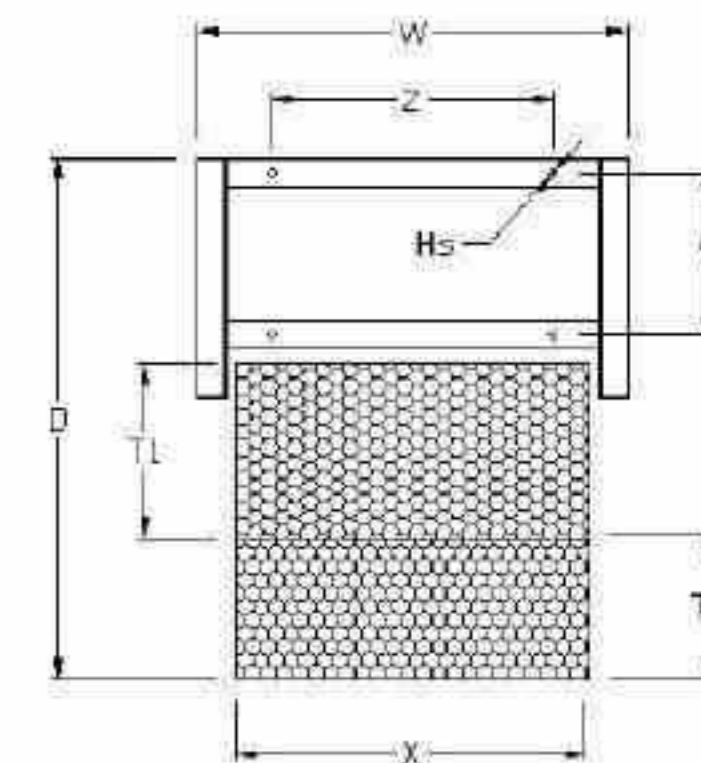

PART NUMBER	L	W	H	D	Hs	A	B	C	T1	T2	A	B	C	KGS
237050G	-	605	480	740	11	320	480	335	250	250	505	230	395	16.9
237051G	-	545	520	770	11	320	500	230	300	250	500	230	405	14.6

Tel: 86-574-82815295/82815296
Web: jilonghardware.com

Fax: 86-574-82815296
E-mail: sales@jilonghardware.com

2E-5

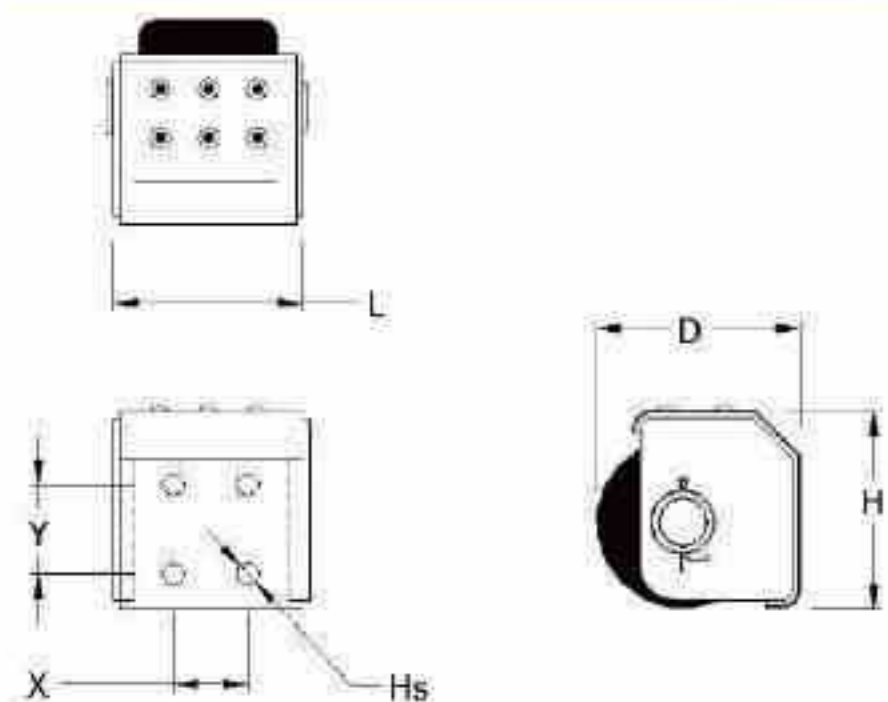

Single Roller

- Heavy duty fabricated steel body
- 28mm axle shaft
- Rubber rollers made from EPDM
- Unique toe grip pattern
- Finish: Body - Galvanised; Axle and Pin - Zinc Plated



PART NUMBER	L	W	H	T	D	Hs	X	Y	KGS
240009	110	-	120	-	120	13	52	52	4.10

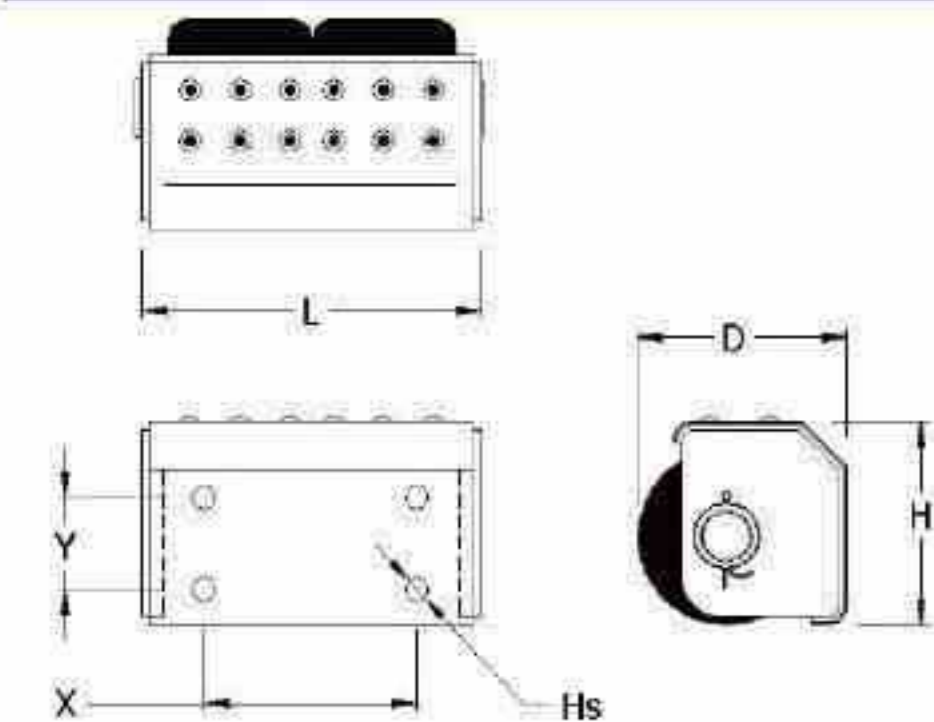

Twin Roller

- Heavy duty fabricated steel body
- 28mm axle shaft
- Rubber rollers made from EPDM
- Unique toe grip pattern
- Finish: Body - Galvanised; Axle and Pin - Zinc Plated



PART NUMBER	L	W	H	T	D	Hs	X	Y	KGS
240010	190	-	120	-	120	13	120	52	6.25

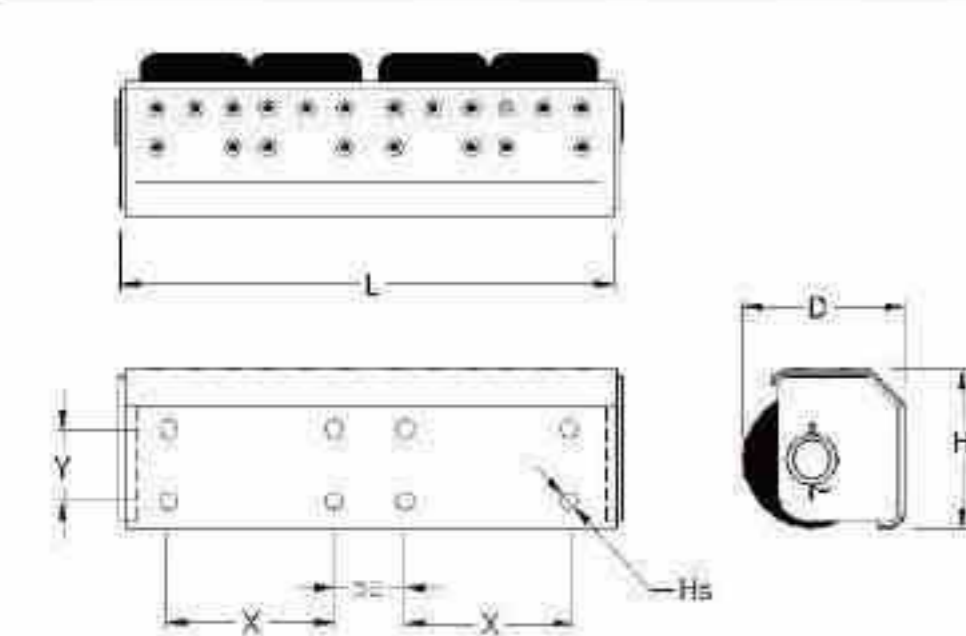

Quad Roller

- Heavy duty fabricated steel body
- 28mm axle shaft
- Rubber rollers made from EPDM
- Unique toe grip pattern
- Finish: Body - Galvanised; Axle and Pin - Zinc Plated



PART NUMBER	L	W	H	T	D	Hs	X	Y	KGS
240011	370	-	120	-	120	13	120	52	11.45



Replacement Rubber Roller

- Suitable for 28mm axle shaft
- Made from EPDM

PART NUMBER	L	W	H	T	D	Hs	X	Y	KGS
240012	-	-	-	-	120	-	-	-	1.44

Replacement Axle Kit

- Comes in three lengths



PART NUMBER	TYPE	L	W	H	T	D	Hs	X	Y	KGS
240015	Single	-	-	-	-	-	-	-	-	-
240013	Twin	-	-	-	-	-	-	-	-	-
240014	Quad	-	-	-	-	-	-	-	-	-

Replacement Bolt Kit



PART NUMBER	TYPE	L	W	H	T	D	Hs	X	Y	KGS
240016	Single	-	-	-	-	-	-	-	-	-
240017	Twin	-	-	-	-	-	-	-	-	-
240018	Quad	-	-	-	-	-	-	-	-	-

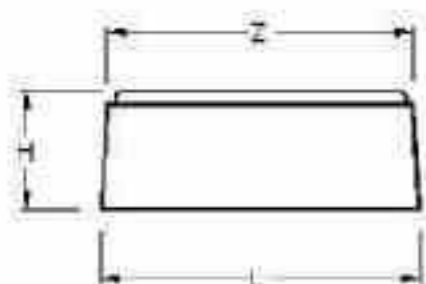
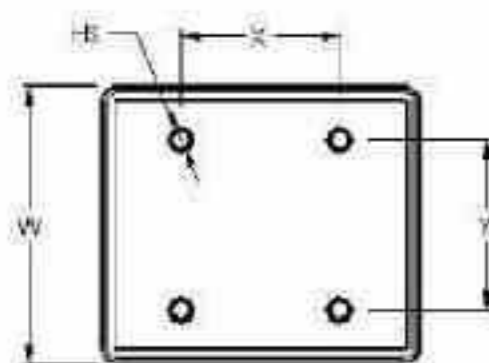
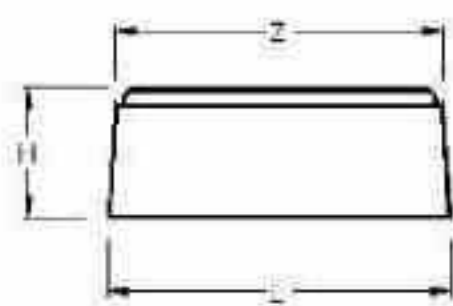
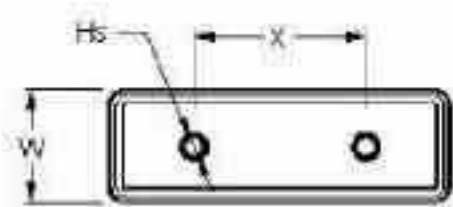

Solid Rubber Buffer

- Manufactured in EPDM
- Various sizes available
- All supplied with thru holes for chassis mounting



PART NUMBER	L	W	H	T	D	Hs	X	Y	Z	KGS
240001	345	100	108	-	-	12	200	-	325	3.55
240002	240	80	90	-	-	12	120	-	230	1.75
240003	195	80	80	-	-	12	90	-	180	1.25
240004	125	80	90	-	-	10	65	-	115	0.90
240005	210	50	58	-	-	10	125	-	178	0.60
240020	200	150	85	-	-	10	116	78	195	2.52

Rubber Wheel Chock

- Manufactured in EPDM
- Sizes available for 17.5", 19.5" and 22.5" wheels

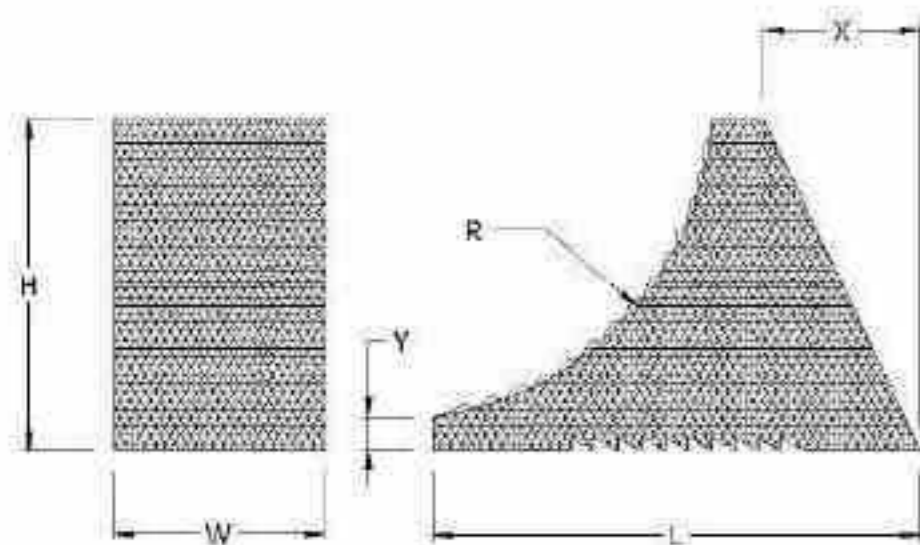

PART NUMBER	L	W	H	R	D	Hs	X	Y	Z	KGS
240006	200	115	120	360	-	-	0	20	-	1.80
240007	265	122	165	460	-	-	70	20	-	3.40
240008	250	170	200	560	-	-	30	45	-	5.60

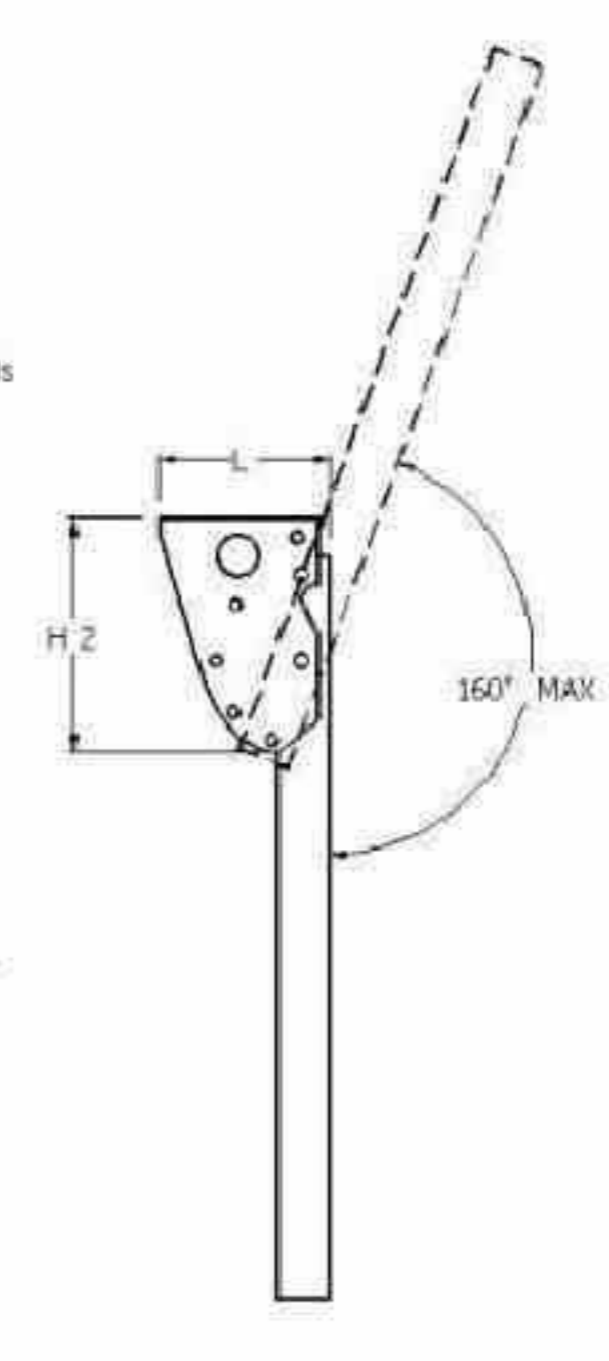
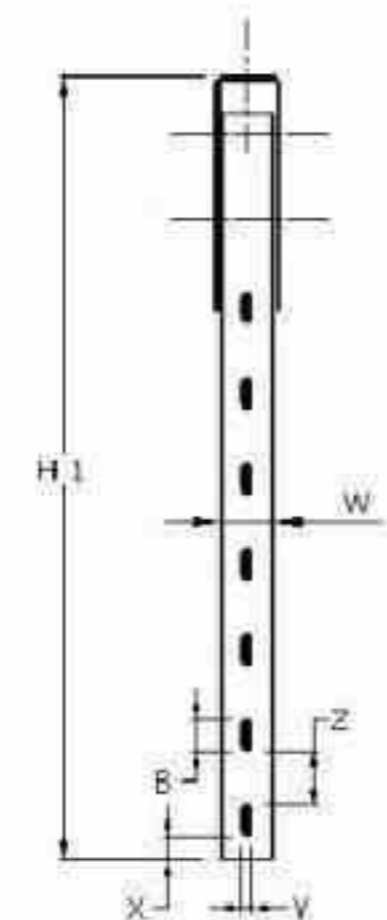
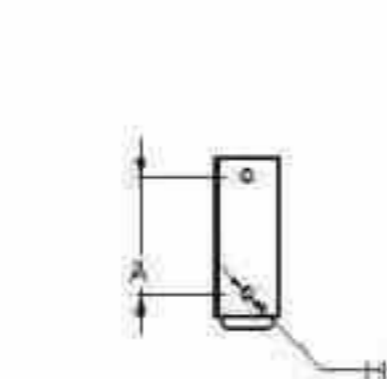

Hinge-Up Side Guard Leg

- Suitable for trucks or trailers
- For under-body mounting
- Variable lift and pin options
- Zinc plated to BS EN 12329:2000
- Galvanised and Stainless options available
- Fixing kit supplied with Type 'A' version
- Front mounting channel for lateral rails is pre-punched with 10mm slotted holes



Type 'A' Head

Supplied with removable security lock pin with 'R' clip and PVC rope



Type 'B' Head

Supplied with removable security cotter pin



PART NUMBER	HEAD	L	W	H1	T	Hs	A	B	X	Y	Z	KGS
233064	B	150	40	460	2.5	12.5	110	40	45	10	30	1.92
233066	B	150	40	720	2.5	12.5	110	40	45	10	30	2.45
233067	A	150	50	740	3	12.5	110	30	23	10	50	3.50
233068	A	150	50	800	3	12.5	110	30	23	10	50	3.68



contents

handbrakes - 3A

pulleys & compensators - 3B

cables & components - 3C

clevis forks & pins - 3D

braking components



Replacement Fixing Kit

- Suitable for type A hinged side guard legs only
- Finish: Zinc Plated



PART NUMBER	L	W	H	T	D	Hs	X	Y	KGS
233072	-	-	-	-	-	-	-	-	-



Replacement Fixing Kit

- Suitable for type B hinged side guard legs only
- Finish: Zinc Plated



PART NUMBER	L	W	H	T	D	Hs	X	Y	KGS
233089	-	-	-	-	-	-	-	-	-

Bolt-On Pressed Side Guard

- Manufactured in pre-galv material - 2mm thick
- Can be supplied in left and right-handed forms
- Finish: Galvanised

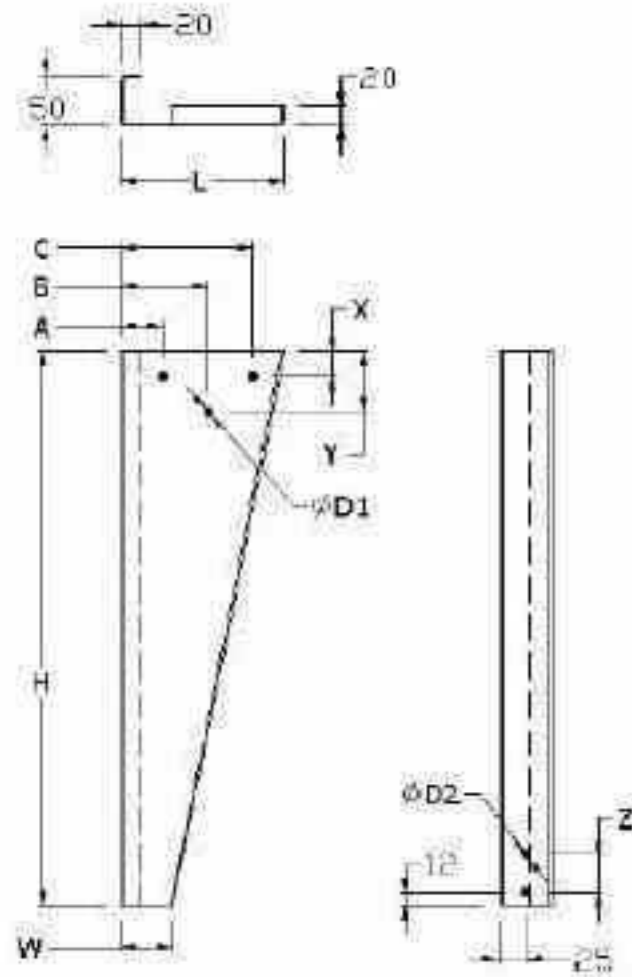

PART NUMBER	L	W	H	T	D1	D2	A	B	C	X	Y	Z	KGS
233084	150	50	850	2	9	9	38	80	122	25	80	110	2.28
233085	150	50	550	2	9	9	40	80	125	25	60	40	1.45



Handbrake Tensioner

- One-piece fabricated base plate
- Available in left or right handed versions
- Minimum maintenance required
- PVC sleeve fitted as standard
- Finish is BS EN 12329:2000 BZP
- Powder coating to BS4950

SPECIFICATION

Product Reference Codes

Left Hand 234002A
Right Hand 234001A

Lever Tensioner

Lever Length 550mm
Thickness 8mm
Applied Finish Zinc Plated

Base Mounting Detail

Centres 115mm Pcd
Hole Diameters 3x11mm
Material Thickness 10mm
Applied Finish Zinc Plated

Drum Tensioner

Diameter 70mm
Applied Face 20mm
Applied Finish EPD Black
Cable Diameter 6-8mm Nom
Take-up P/tooth 7mm
Take-up P/rev 225mm
No. of Teeth 36
Efficiency 80%

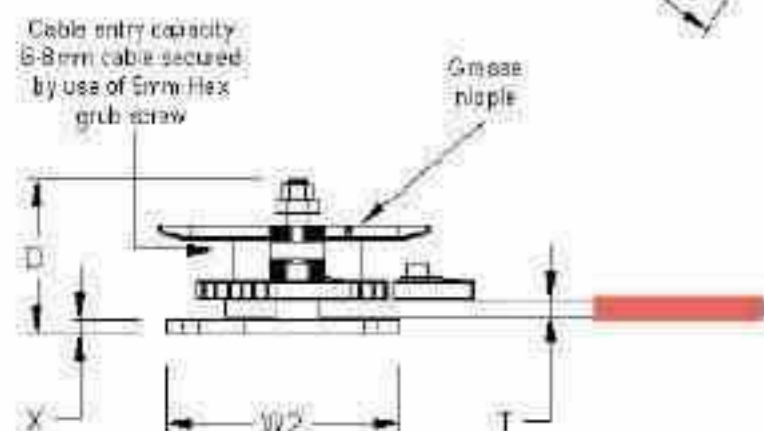
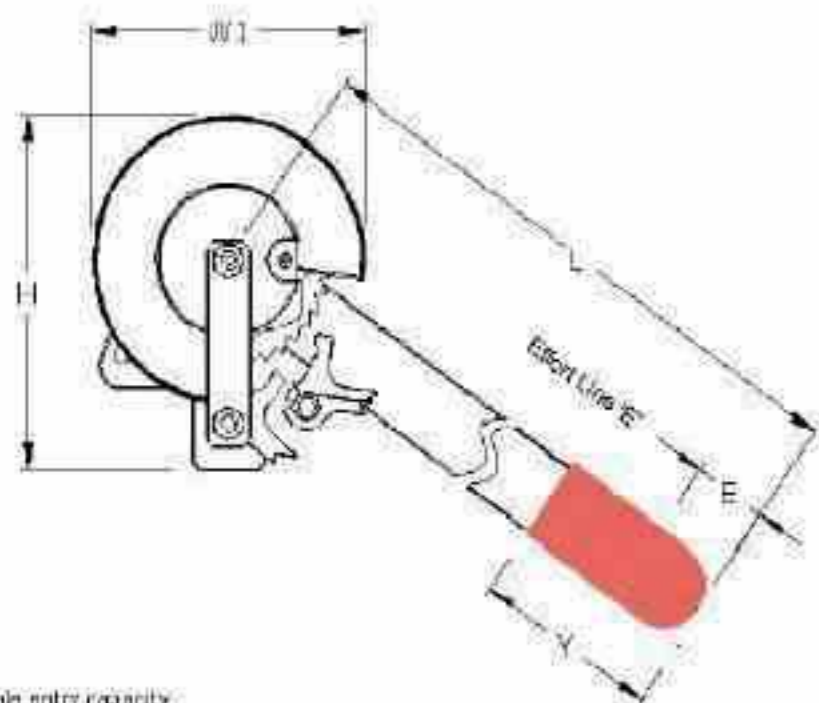

PART NUMBER	L	W1	W2	H	T	D	E	X	Y	Z	KGS
234001A	550	57	150	185	8	80	40	10	155	28	4.6
234002A	550	57	150	185	8	80	40	10	155	28	4.6

Handbrake Tensioner

- One-piece fabricated full body
- Primarily right handed; left hand available on request
- Minimum maintenance required
- PVC sleeve fitted as standard
- Finish is BS EN 12329:2000 BZP
- Powder coating to BS4950

SPECIFICATION

Product Reference Codes

Right Hand 234003A

Lever Tensioner

Lever Length 550mm
Thickness 8mm
Applied Finish BZP

Base Mounting Detail

Centres 115mm Pcd
Hole Diameters 3x11mm
Material Thickness 10mm
Applied Finish BZP

Drum Tensioner

Diameter 70mm
Applied Face 20mm
Applied Finish EPD Black
Cable Diameter 6-8mm Nom
Take-up P/tooth 4mm
Take-up P/rev 225mm
No. of Teeth 36
Efficiency 60%

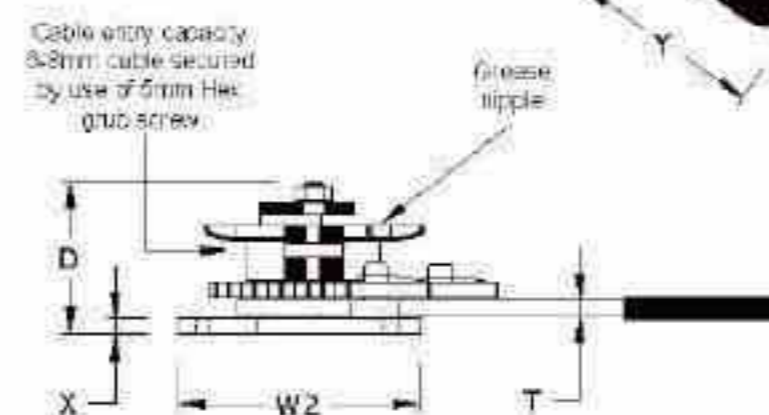
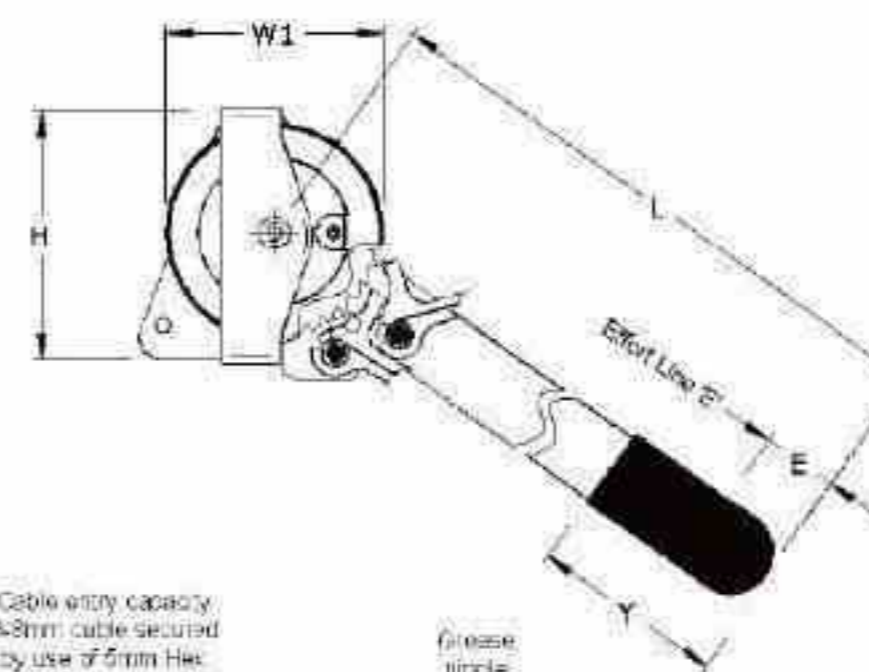

PART NUMBER	L	W1	W2	H	T	D	E	X	Y	KGS
234003A	550	115	125	135	8	70	40	10	130	4.05

European Tensioner

- Hollow box tube development
- Universally handed
- Minimum maintenance required
- Grease nipple to main body
- Manual apply and release for added security
- Meets with TUV approval
- Adjustable handle positioning
- Powder coated to BS4950

SPECIFICATION

Product Reference Code

Tensioner Assembly 234010

Rotary Handle

Handle Length 210mm
 Handle Crank 115mm
 Handle Diameter 16mm
 Rotation 360°

Tensioner Body

Development 60x40x3mm
 Overall Length 245mm
 Cable Wheel Dia 85mm
 Cable Diameter 6-8mm
 Rotations to Extend 49
 Captive Thread M16
 Efficiency 45%

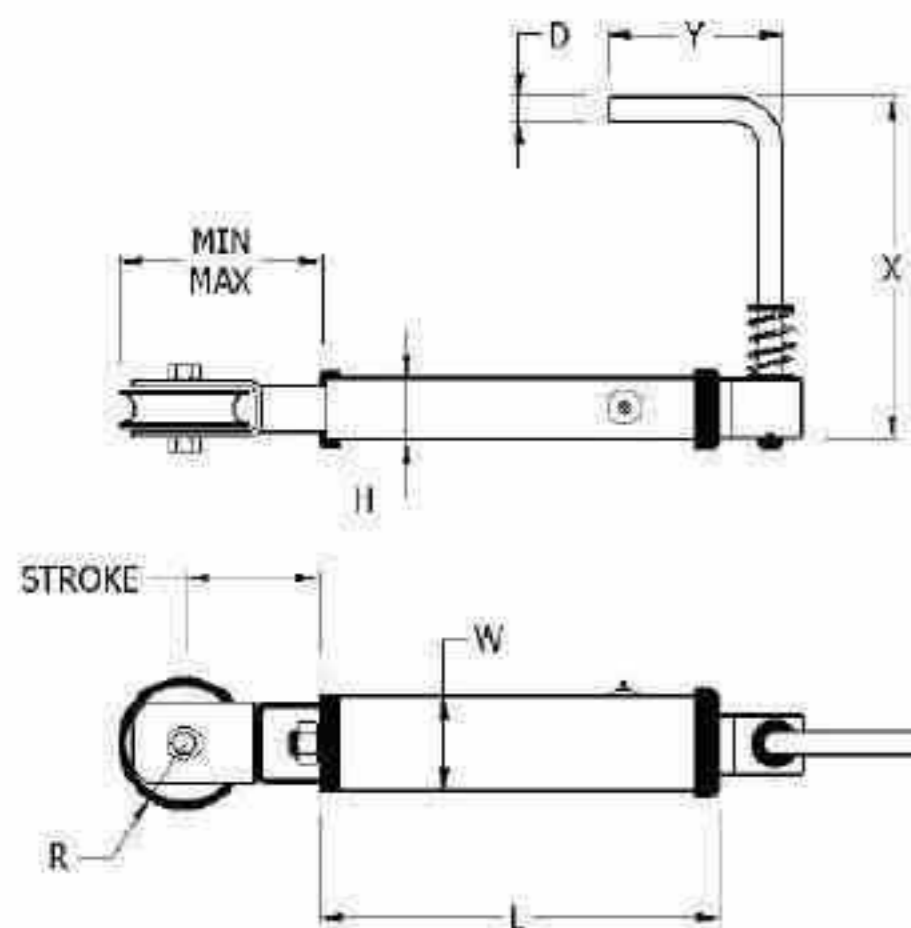

PART NUMBER	L1	W	H	R	D	STROKE	MIN/MAX	X	Y	KGS
234010	245	60	40	82	16	185	118/203	210	110	4.12

3A-3

Tel: 86-574-82815295/82815299
 Web: jilhardware.com

Fax: 86-574-82815296

E-mail: sales@jilhardware.com

Single Pulley Anchor Bracket

- Steel mounting pressing
- Suitable for 6mm cable diameters
- Removable pulley wheel
- Finish: Zinc Plated

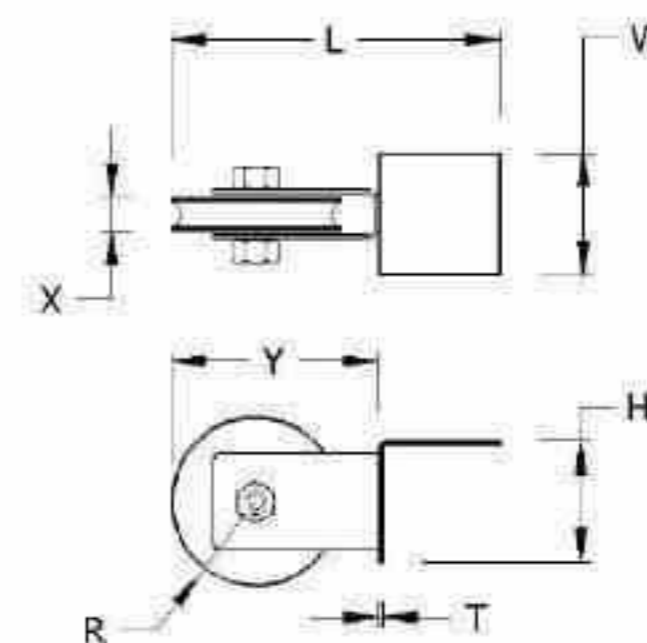

PART NUMBER	L	W	H	T	R	Hs	X	Y	KGS
234011	135	50	50	2	35	-	13	82	0.55

Twin Pulley Anchor Guide

- Steel mounting pressing
- Suitable for 6mm cable diameters
- Removable pulley wheels
- Single/Twin axle applications
- Finish: Zinc Plated

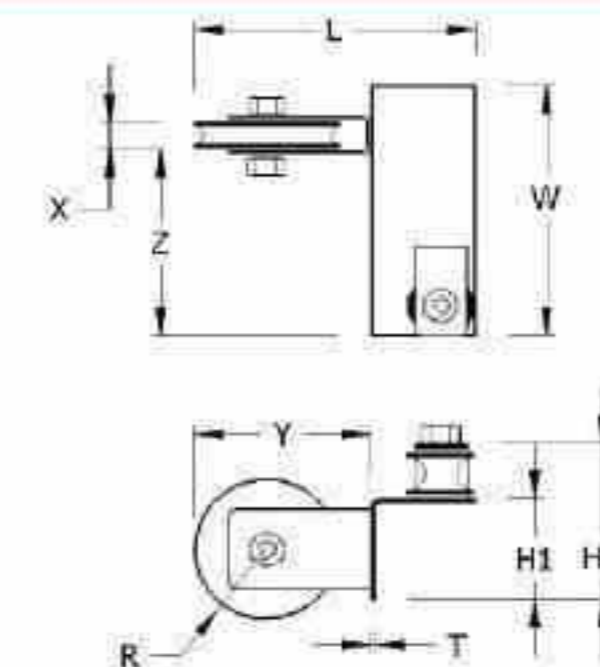

PART NUMBER	L	W	H1	H2	T	R	X	Y	Z	KGS
234012	130	125	50	78	2	35	13	82	100	0.85

Roller Guide Anchor Bracket

- Steel mounting pressing
- Suitable for 6mm cable diameters
- Removable roller wheel
- Finish: Zinc Plated

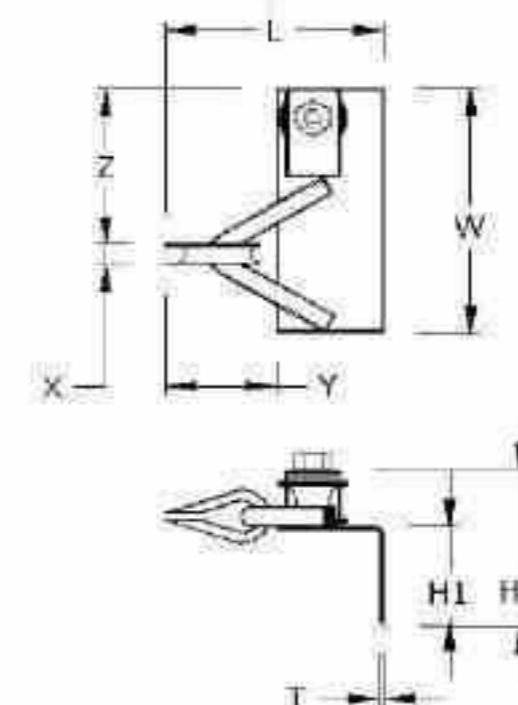

PART NUMBER	L	W	H1	H2	T	Hs	X	Y	Z	KGS
234015	76	125	50	78	2	-	10	55	80	0.51

3B-I

Tel: 86-574-82815295/82815299
 Web: jilhardware.com

Fax: 86-574-82815296

E-mail: sales@jilhardware.com

Handbrake Compensator

- Steel fabricated assembly
- Suitable for 6mm cable diameters
- Removable roller wheel
- Tensile 8.8 grade thru bolt c/w nuts
- Bar threaded both ends M12x1.75 x 20mm
- Finish: Zinc Plated

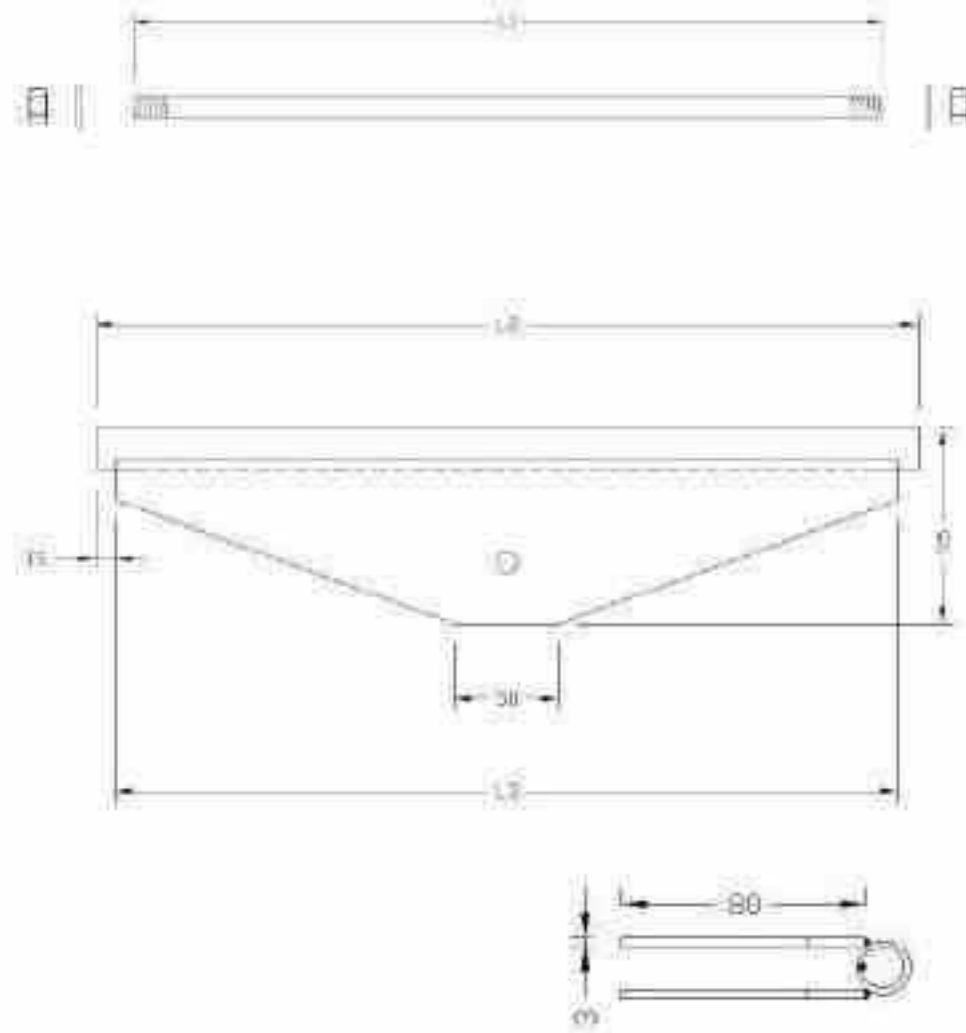

PART NUMBER	L1	L2	L3	W	H	T	Hs	X	Y	KGS
234365	410	340	310	-	-	-	-	-	-	2.10
234395	450	375	345	-	-	-	-	-	-	2.18
234425	470	405	375	-	-	-	-	-	-	2.25
234455	495	435	405	-	-	-	-	-	-	2.35
234620	680	600	570	-	-	-	-	-	-	2.90



Steel Cable

- 7 core element construction (see table below)
- Supplied in a reel or on a drum depending on length
- Finish: Galvanised ISO1461

PART NUMBER	Cable Dia' (mm)	MBL (tons)	Cable Length (mm)	Element	Shipping Form	KGS
245010	1.5	0.15	1.83	7x7	COIL	0.03
245011	1.5	0.15	500	7x7	COIL	6.20
245012	4	1.04	30	7x7	COIL	2.20
245018	6	2.33	5	7x7	COIL	0.74
245013	6	2.33	15	7x7	COIL	1.80
245014	6	2.33	30	7x7	COIL	4.40
245015	6	2.33	100	7x7	REEL	15.0
245016	6	2.33	2	7x7	COIL	0.30
245017	8	4.15	100	7x7	REEL	21.3

Wire Rope Thimble

- Sizes other than those shown may be available on request
- Can be bagged up in kit quantities - please enquire
- Finish: Galvanised ISO1461



PART NUMBER	Cable Diameter	KGS
245001	2 x 6mm	-
245002	2 x 8mm	-

Wire Rope Grip

- Sizes other than those shown may be available on request
- Can be bagged up in kit quantities - please enquire
- Finish: Galvanised ISO1461



PART NUMBER	Cable Diameter	KGS
245003	2 x 5mm	-
245004	2 x 6mm	-
245005	2 x 8mm	-



PULLEY

CAPSTAN

Replacement Wheel Kit

- Pulley or capstan
- Complete with bush
- Finish: ZYP

PART NUMBER	TYPE	Suits	Diameter	Thickness	KGS
234016	PULLEY	Compensators / Brackets	67	18	0.30
234017	CAPSTAN	Brackets	24	32	0.06



Clevis Fork

- Fully hardened machined fork
- Imperial threads unified to class 2B
- Metric threads unified to class 6H
- Assembled complete
- Finish: Zinc Plated

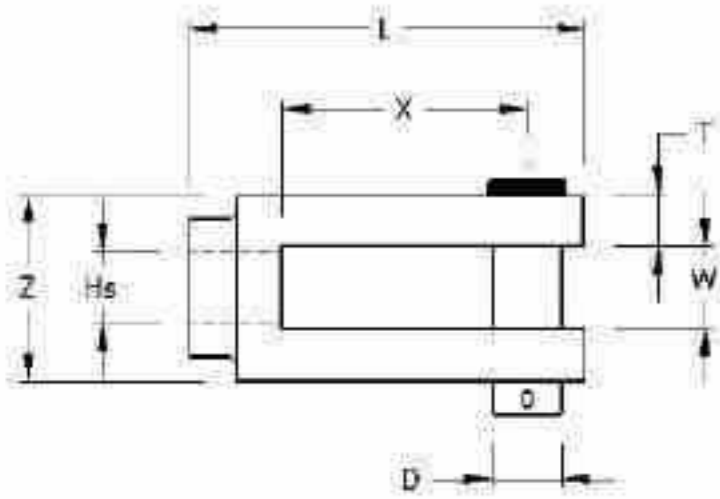

PART NUMBER	L	W	D	H	Hs	T	X	Y	KGS
234018	65	14.5	1/2"	25	5/8" UNF	8.5	41	57	0.26
234019	65	14.5	1/2"	25	M16x1.5	8.5	41	57	0.26
234020	65	14.5	14mm	25	M16x1.5	8.5	41	57	0.26
234021	84	14.5	14mm	25	M16x1.5	8.5	55	76	0.32
234022	65	14.5	16mm	25	M16x1.5	8.5	41	57	0.26

Clevis Pin

- Case hardened
- Supplied singles or in packs - please enquire
- Finish: Zinc Plated

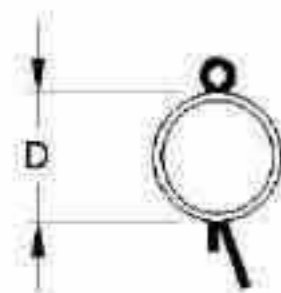
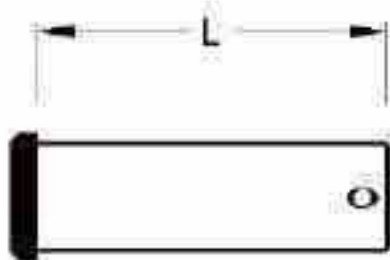

PART NUMBER	L	D	KGS
234023	40	10mm	0.03
234024	42.5	1/2"	0.05
234025	42.5	14mm	0.06
234026	42.5	16mm	0.07



A		Cotter Pin:	
Access Step:		• D' Shaped Cotter Pin	1A-3
• 2 Rung Pull-Out Platform	2E-4	• D' Shaped Flat Cotter	1A-3
• 2 Rung Pull-Out	2E-2	• Round Cotter Pin	1A-3
• 2 Rung Roofer	2E-3	Coupling Boxes:	
• 3 Rung Pull-Out Platform	2E-4	• High-Mount 2 Line Coupling Box	2C-1
• 3 Rung Pull-Out	2E-2	• High-Mount 3 Line Coupling Box	2C-1
• Flat Bar Hooped	2E-1	• Mid-Mount 2 Line Coupling Box	2C-1
• Folding Step	2E-5	• Slim-Line 3 Line Coupling Box	2C-1
• Tail-Lift Tuck-Away Step	2E-1	• Uni-Trink Rolling Coupling System	2C-2
Anti Luce:	See: Stayfast Latch	Crate Hooks	1A-4
Anti Sail Bar:	2A-5	Curtain Straps:	
Axle Shaft:	2D-1	• Bottom Strap with Rave Hook	1D-3
B		• Internal Strap with Rave Hook & Snap Hook	1D-3
Backplate:	2A-3	D	
Binder, Replacements:	1F-5	Door Blades:	1G-1
Bottom Strap with Rave Hook:	1D-3	Door Gear:	1G-3
Brackets:		Door Retainer:	
• Roller Guide Anchor Bracket	3B-1	• PVC Covered Cable Retainers	1B-1
• Single Pulley Anchor Bracket	3B-1	• Spring Loaded Retainer	1B-1
• Spares	3C-1	E	
• Twin Pulley Anchor Guide:	3B-1	European Tensioner:	3A-3
Buckle:		Eye Bolt:	1F-2
• Overcentre Buckle	1D-1	F	
• Pozi-Plus Overcentre Buckle	1D-1	Ferry Shackles:	1F-3
• Pull Release Buckle	1D-2	Fixing Kits for:	
• Push Release Buckle	1D-2	• 2 Hole Plastic Adjustable Clamp	2A-7
• Slimline Buckle	1D-1	• 2 Hole Steel Adjustable Clamp	2A-7
• Tysafe Buckle	1D-2	• 3 Hole Continental Clamp	2A-7
Buffer, Solid Rubber:	2F-3	• 3 Hole Saddle Strap	2A-7
C		• 4 Hole Saddle Strap	2A-7
Cable:		• 4 Hole Tunnel Pressing and Backplate	2A-7
• Accessories	3C-1	• 4 Hole Tunnel Pressing Only	2A-7
• PVC Door Cable	1B-1	• 6 Hole Tunnel Pressing and Backplate	2A-7
• Security Cable	1C-1	• 6 Hole Tunnel Pressing Only	2A-7
• Steel Cable	3C-1	• Anti Sail Bars	2A-7
• TIR Cable	1C-1	• Side Guard Leg	2G-2
Captain Roller:	3C-1	• Spare Wheel Carriers	2B-3
Cargo Ring:	1F-2	• Tri-Bolt Wing Stay	2A-7
Cargo Strap:	1F-5	Flat Bar Hooped Step:	2E-1
Cargo Winch:	1F-1	Flat Foot:	2D-2
Car Transporter Winch:	1F-1	Flush Fit Panel Lock:	1G-2
Chain:	1A-4	Flush Fit Tee Handle Lock:	1G-2
Clevis Fork:	3D-1	H	
Clevis Pin:	3D-1	Handbrake Compensator:	3B-2
Closed Rave Hook:	1D-3	Handbrake Tensioner:	3A-1, 3A-2
Compensator:	3B-2	Hexagon Extension:	2D-1



Hinges	1G-2	PVC Door Cable	1B-1
Hook and Chain	1A-4	Platform Step	2E-4
Hooks to Crew	1A-4	Q	
Hooped Step	2E-1	Quick Link	1A-5
		L	R
Landing Wheel	2D-2	Ramp Fastener Set	1A-5
Lashing Fork	1F-4	Ratchet Strap:	
Lashing Ring:		• Commercial Ratchet Strap Assembly	1F-5
• Triangular Lashing Ring	1F-4	• Replacement Binder	1F-5
• Under-Floor Lashing Ring	1F-4	• Replacement Strap	1F-5
Leg Accessories:		Rave Drop Down Lashing Fork	1F-4
• Axle Shaft	2D-1	Rave Hook	1D-3
• Flat Foot	2D-2	Recessed Overcentre Lock	1G-1
• Landing Wheel	2D-2	Retainers	1B-1
• Rocking Foot	2D-2	Rocking Foot	2D-2
Link	1A-5	Rope	1F-2
Load Security Rope	1F-2	Rope Grip	3C-1
Locking Gear	1G-3	Rope Hook	1F-3
Locks:		Roller Buffer:	
• Flush Fit Panel Lock	1G-2	• Single Roller	2F-1
• Flush Fit Tee Handle Lock	1G-2	• Double Roller	2F-1
• Plant-On Lock	1G-1	• Quad Roller	2F-1
• Recessed Overcentre Lock	1G-1	• Rubber Roller Replacement	2F-2
M		• Axle Kits	2F-2
Mudwing Poles		• Bolt Kits	2F-2
		N	
Nose Boxes		Rubber:	
Number Plate Holder:		• Roller Buffer	2F-1
• Commercial Square Number Plate Holder	1E-1	• Rubber Wheel Chock	2F-3
• Deep Number Plate Holder	1E-2	• Rubberised U-Bolt Kit	2A-4
• UK Deep & Slimline Number Plate Holder	1E-2	• Solid Rubber Buffer	2F-3
• UK Long Number Plate Holder	1E-1	S	
• UK Square Number Plate Holder	1E-1	Saddle Strap	2A-5
O		Security Cable	1C-1
Overcentre Lock	1G-1	Shackle	1F-4
Overcentre Buckle	1D-1	Shoot Bolt	1A-2
P		Side Guard Leg:	
Pins:		• Bolt-On Pressed Side Guard Leg	2G-2
• D' Shaped Cotter Pin	1A-3	• Hinge-Up Side Guard Leg	2G-1
• D' Shaped Flat Cotter Pin	1A-3	• Replacement Fixing Kit	2G-2
• Round Cotter Pin	1A-3	Slimline Buckle	1D-1
• Spring Loaded Sword Pin	1A-2		
Plant-On Lock	1G-1		
Pressed Rave Hook	1D-3		
Pull Release Buckle	1D-2		
Pulley Wheel	3C-1		
Push Release Buckle	1D-2		



		W	
Spare Wheel Carriers:		Wasted Ring	1D-4
• Side Mounted Spare Wheel Carrier	2B-1, 2B-2	Wheel Carriers:	See: Spare Wheel Carriers
• Under Chassis Mounted S.W.C. - Variable PCD	2B-2	Wheel Chock:	
• Fixing Kit for 232035 / 036 / 037	2B-3	• Wheel Chock	2B-4
• Lifting Bar Kit	2B-3	• Wheel Chock Holder	2B-4
• Winch Cable	2B-3	• Rubber Wheel Chock	2F-3
• Winch Handle	2B-3	Winch:	
Spring Hook:		• Strap Winch	1F-1
• To Crue	1A-4	• Car Transporter Winch	1F-1
• With Chain	1A-4	• Cargo Winch	1F-1
Spring Loaded Sword Pins	1A-2	Winding Handle	2D-1
Stayfast Latch:		Wing Stay:	
• Bolt-On Stayfast Latch	1A-1	• Mono-Bolt Wing Stay	2A-1
• Brewery Stayfast Latch	1A-2	• Tri-Bolt Wing Stay	2A-2
• Weld-On Stayfast Latch	1A-1	• Wing Stay Tunnel Pressing	2A-3
Steel Cable		• Wing Stay Backing Plate	2A-3
Stops		• Adjustable Continental Wing Stay Clamp	2A-6
Strap:		• Continental Style Wing Stay Clamp	2A-6
• Bottom Strap with Rave Hook	1D-3	• Plastic Adjustable Wing Stay Clamp	2A-6
• Internal Strap with Rave Hook & Snap Hook	1D-3	• Wing Stay U-Bolt Clamp	2A-4
• Replacement Straps	1F-5	• Rubberised U-Bolt Kit	2A-4
Sword Pin	1A-2	• Fixing Kits	2A-7
T		• Saddle Strap	2A-5
Tail Lift Tuckaway Step	2E-1	Wire Rope Grip	3C-1
Tensioner:	3A-1 to 3A-3	Wire Rope Thimble	3C-1
Thimble (Wire Rope)	3C-1		
TIR Cable	1C-1		
Transporter Winch	1F-1		
Triangular Lashing Ring with Plate	1F-4		
Tuckaway Step	2E-1		
Tunnel Pressing	2A-3		
Twin-Fix Plate:			
• Twin-Fix Clamp Plate	1D-4		
• Twin-Fix Plate c/w Nylon Nuts	1D-4		
• Twin-Fix Sandwich Plate Assembly	1D-4		
Tysafe Buckle	1D-2		
U			
U-Bolt:			
• Rubberised U-Bolt Kit	2A-4		
• Wing Stay U-Bolt Clamp	2A-7		
Un-Bushed Door Gear Set	1G-3		
Under-Floor Lashing Ring:	1F-4		



231		Coupling Boxes		233015		Rubberised U-Bolt Kit - 34mm		2A-4																																																																																																																																				
231001	High-Mount 3 Line Coupling Box	2C-1	233016	Continental Style Wing Stay Clamp	2A-6	233017	Tri-Bolt Wing Stay 'C' Type - 800mm	2A-2	233018	Tri-Bolt Wing Stay 'C' Type - 700mm	2A-2	233019	Tri-Bolt Wing Stay 'S' Type - 760mm	2A-2	233020	Tri-Bolt Wing Stay 'S' Type - 670mm	2A-2	233021	Adjustable Continental Wing Stay Clamp	2A-6	233023	Fixing Kit for Tri-Bolt Wing Stay - All Sizes	2A-7	233024	Fixing Kit for 4 Hole Tunnel Pressing Only - All Sizes	2A-7	233025	Fixing Kit for 6 Hole Tunnel Pressing Only	2A-7	233026	Fixing Kit for 3 Hole Continental Clamp - 233016	2A-7	233027	Fixing Kit for 4 Hole Saddle Strap - 233014	2A-7	233028	Fixing Kit for 3 Hole Saddle Strap - 233013	2A-7	233029	Anti Sail Bar - 370x780mm	2A-7	233030	Anti Sail Bar - 370x870mm	2A-7	233031	Fixing Kit for 4 Hole Tunnel Pressing and Backplate	2A-7	233032	Fixing Kit for 6 Hole Tunnel Pressing and Backplate	2A-7	233034	Wing Stay Tunnel Pressing - 280mm / 42mm	2A-3	233035	Wing Stay Tunnel Pressing - 280mm / 52mm	2A-3	233037	Wing Stay Tunnel Pressing - 400mm / 42mm	2A-3	233038	Wing Stay Tunnel Pressing - 400mm / 52mm	2A-3	233043	Ferry Shackle 'C' Type - 20mm / 1.25 Tonnes	1F-3	233044	Mono-Bolt Wing Stay 'C' Type - 760mm	2A-1	233045	Mono-Bolt Wing Stay 'C' Type - 460mm	2A-1	233046	Mono-Bolt Wing Stay 'C' Type - 380mm	2A-1	233047	Mono-Bolt Wing Stay 'S' Type - 460mm	2A-1	233048	Tri-Bolt Wing Stay 'C' Type - 670mm	2A-2	233049	Tri-Bolt Wing Stay 'S' Type - 670mm	2A-2	233050	Adjustable Continental Wing Stay Clamp - 42mm dia	2A-6	233054	Wing Stay U-Bolt Clamp - 34mm dia	2A-4	233055	Wing Stay U-Bolt Clamp - 38mm dia	2A-4	233056	Wing Stay U-Bolt Clamp - 42mm dia	2A-4	233057	Wing Stay U-Bolt Clamp - 48mm dia	2A-4	233058	Ferry Shackle 'P' Type - 26mm / 1.25 Tonnes	1F-3	233059	Mono-Bolt Wing Stay 'S' Type - 760mm	2A-1	233060	Ferry Shackle 'C' Type - 23mm / 2.25 Tonnes	1F-3	233061	Ferry Shackle 'C' Type - 26mm / 3.25 Tonnes	1F-3	233062	Ferry Shackle 'P' Type - 23mm / 2.25 Tonnes	1F-3	233063	Ferry Shackle 'P' Type - 26mm / 3.25 Tonnes	1F-3	233064	Hinge-Up Side Guard Leg - 460mm	2G-1	233066	Hinge-Up Side Guard Leg - 570mm	2G-1	233067	Hinge-Up Side Guard Leg - 700mm	2G-1	233068	Hinge-Up Side Guard Leg - 760mm	2G-1	233071	Adjustable Continental Wing Stay Clamp - 59mm dia	2A-6	233072	Replacement Fixing Kit	2G-2	233075	Anti Sail Bar - 370x480mm	2A-5	233076	Anti Sail Bar - 370x680mm	2A-5



234		Handbrakes & Compensators		236		Body Fasteners		
234001	Handbrake Tensioner RH	3A-1	234002	Handbrake Tensioner LH	3A-1	236000	Shoot Bolt - 135mm	1A-2
234003	Handbrake Tensioner RH	3A-2	234010	European Tensioner	3A-3	236001	Shoot Bolt - 123mm	1A-2
234011	Single Pulley Anchor Bracket	3B-1	234012	Twin Pulley Anchor Guide	3B-1	236002	Shoot Bolt - 235mm	1A-2
234015	Roller Guide Anchor Bracket	3B-1	234016	Replacement Pulley Wheel	3C-1	236003	'D' Shaped Cotter Pin - without chain	1A-3
234017	Replacement Capstan Roller	3C-1	234018	Clevis Fork 5/16" UNF	3D-1	236004	Spring Loaded Sword Pin - 148mm	1A-2
234019	Clevis Fork M16	3D-1	234020	Clevis Fork M16	3D-1	236005	Spring Loaded Sword Pin - 122mm	1A-2
234021	Clevis Fork M16	3D-1	234022	Clevis Fork M16	3D-1	236006	Spring Loaded Sword Pin - 176mm	1A-2
234023	Clevis Pin 18mm	3D-1	234024	Clevis Pin 1/2"	3D-1	236007	Round Cotter Pin	1A-3
234025	Clevis Pin 14mm	3D-1	234026	Clevis Pin 16mm	3D-1	236008	'D' Shaped Flat Cotter	1A-3
234365	Handbrake Compensator 340mm	3B-2	234395	Handbrake Compensator 375mm	3B-2	236009	'D' Shaped Cotter Pins - with Chain	1A-3
234425	Handbrake Compensator 405mm	3B-2	234455	Handbrake Compensator 455mm	3B-2	236010	Weld-On Stayfast Latch - 9 x 9.5mm	1A-1
234620	Handbrake Compensator 600mm	3B-2	235000	PVC Covered Cable Retainers - 250x320	1B-1	236011	Weld-On Stayfast Latch - 12 x 12.5mm	1A-1
235000	PVC Covered Cable Retainers - 300x370	1B-1	235001	PVC Covered Cable Retainers - 350x420	1B-1	236012	Bolt-On Stayfast Latch - M8 x 20mm	1A-1
235002	PVC Covered Cable Retainers - 400x470	1B-1	235003	PVC Covered Cable Retainers - 450x520	1B-1	236013	Bolt-On Stayfast Latch - M8 x 38mm	1A-1
235005	PVC Covered Cable Retainers - 450x520	1B-1	235006	Spring Loaded Retainers - Left Hand	1B-1	236014	Bolt-On Stayfast Latch - M12 x 25mm	1A-1
237002	Flat Bar Hooped Step	2E-1	237003	Tail-Lift Tuck-Away Step	2E-1	236015	Bolt-On Stayfast Latch - M12 x 34mm	1A-1
237005G	2 Rung Pull-Out Platform Step	2E-4	237008	2 Rung Roofer Step	2E-3	236016	Bolt-On Stayfast Latch - M12 x 76mm	1A-1
237016	2 Rung Pull-Out Step	2E-2	237039	3 Rung Pull-Out Step	2E-2	236017	Brewery Stayfast Latch	1A-1
237045G	3 Rung Pull-Out Platform Step	2E-4	237050G	Folding Step - Angled Frame	2E-5	236019	TIR Cable 30.4mtrs	1C-1
237050G	Folding Step - Angled Frame	2E-5	237051G	Folding Step - RHS Frame	2E-5	236020	TIR Cable 32.4mtrs	1C-1
237051G	Folding Step - RHS Frame	2E-5				236021	TIR Cable 34.4 mtrs	1C-1
						236022	TIR Cable 36.4mtrs	1C-1
						236023	TIR Cable 40.4mtrs	1C-1
						236025	TIR Cable 16.7mtrs	1C-1
						236026	TIR Cable 250mtrs	1C-1
						236027	TIR Cable 500mtrs	1C-1
						236029	Security Cable 16.7mtrs	1C-1
						236030	Security Cable 34mtrs	1C-1
						236034	Spring Loaded Sword Pin - 112mm	1A-2
						236036	Ramp Fastener Set	1A-5



238 Landing Legs / Container Equipment		240016 Bolt Kit - for Single Roller		2F-2
238000	Rocking Foot - 51mm Axle	2D-2	240017 Bolt Kit - for Twin Roller	2F-2
238001	Rocking Foot - 44mm Axle	2D-2	240018 Bolt Kit - for Quad Roller	2F-2
238002	Flat Foot - 51mm Axle	2D-2	240020 Solid Rubber Buffer - 200x130x85	2F-3
238003	Axle Shaft - 385x365	2D-1	242 Load Restraint	
238004	Landing Wheel - 51mm Axle	2D-2	242000 Car Transporter Winch - Left Hand	1F-1
238005	Landing Wheel - 44mm Axle	2D-2	242001 Car Transporter Winch - Right Hand	1F-1
238006	Flat Foot - 44mm Axle	2D-2	242003 Commercial Ratchet Strap Assembly - 50mm x 8mtrs	1F-5
238007	Axle Shaft - 200x180	2D-1	242004 Commercial Ratchet Strap Assembly - 50mm x 10mtrs	1F-5
238009	Axle Shaft - 200x180	2D-1	242005 Internal Strap with Rave Hook & Snap Hook	1D-3
238010	Winding Handle - Tubular / Slotted	2D-1	242007 Bottom Strap with Rave Hook	1D-3
238011	Winding Handle - Solid / Slotted	2D-1	242011 Cargo Winch	1F-1
238012	Winding Handle - Solid / Hexagon	2D-1	242017 Forged Eye-bolt and Ring - 110mm	1F-2
238013	Hexagon Extension - 60mm	2D-1	242018 C Weld-on Steel Rope Hook - 58mm	1F-2
238014	Hexagon Extension - 85mm	2D-1	242019 C Weld-on Steel Rope Hook - 60mm	1F-2
238015	Hexagon Extension - 265mm	2D-1	242020 Commercial Ratchet Strap Assembly - 25mm x 5mtrs	1F-5
239 Hook & Chain		242021	Cargo Ring	1F-2
239003	Spring Hook to Crut - 50mm	1A-4	242022 Forged Eye-bolt and Ring - 155mm	1F-2
239004	Spring Hook to Crut - 63mm	1A-4	242023 Commercial Ratchet Strap Assembly - 35mm x 5mtrs	1F-5
239005	Spring Hook to Crut - 75mm	1A-4	242024 Load Security Rope - 220mtrs	1F-2
239006	Spring Hook to Crut - 88mm	1A-4	242026 Triangular Lashing Ring with Plate - 175mm	1F-4
239007	Spring Hook to Crut - 102mm	1A-4	242027 Commercial Ratchet Strap Assembly - 50mm x 12mtrs	1F-5
239008	Spring Hook with Chain - 63mm x 9 link	1A-4	242028 Triangular Lashing Ring with Plate - 135mm	1F-4
239009	Spring Hook with Chain - 75mm x 9 link	1A-4	242029 Rave Drop Down Lashing Fork	1F-4
239010	Spring Hook with Chain - 75mm x 14 link	1A-4	242030 Load Security Rope - 27.5mtrs	1F-2
239011	Spring Hook with Chain - 88mm x 14 link	1A-4	242031 Load Security Rope - 36.5mtrs	1F-2
239012	Spring Hook with Chain - 102mm x 14 link	1A-4	242034 Push Release Buckle for 45mm Webbing	1D-2
239013	Quick Link - 70mm	1A-5	242035 Overcentre Buckle for 50mm Webbing	1D-1
239014	Quick Link - 83mm	1A-5	242036 Overcentre Buckle for 50mm Webbing	1D-1
239015	Quick Link - 108mm	1A-5	242037 Tysafe Buckle for 50mm Webbing	1D-2
239019	Mild Steel Welded Chain	1A-4	242038 Pull Release Buckle for 50mm Webbing	1D-2
240 Rubber (Buffers / Rollers / Chocks)		242039	Pull Release Buckle for 50mm Webbing	1D-2
240001	Solid Rubber Buffer - 145x100x108	2F-3	242040 Replacement Binder - 50mm Webbing	1F-5
240002	Solid Rubber Buffer - 240x80x90	2F-3	242041 Replacement Strap - 10mtrs x 50mm	1F-5
240003	Solid Rubber Buffer - 195x80x80	2F-3	242042 Replacement Strap - 8mtrs x 50mm	1F-5
240004	Solid Rubber Buffer - 125x80x90	2F-3	242043 Closed Rave Hook	1D-3
240005	Solid Rubber Buffer - 210x50x58	2F-3	242044 Replacement Binder - 35mm Webbing	1F-5
240006	Rubber Wheel Chock - 200x115x120	2F-3	242045 Replacement Strap - 5mtrs x 35mm	1F-5
240007	Rubber Wheel Chock - 265x122x165	2F-3	242047 Push Release Buckle for 45mm Webbing	??
240008	Rubber Wheel Chock - 250x170x200	2F-3	242048 Slimline Buckle for 45mm Webbing - 146mm	1D-1
240009	Single Roller	2F-1	242049 Slimline Buckle for 45mm Webbing - 172mm	1D-1
240010	Double Roller	2F-1	242050 Pozi-Plus Overcentre Buckle for 50mm Webbing	1D-1
240011	Quad Roller	2F-1	242052 Overcentre Buckle for 50mm Webbing	1D-1
240012	Rubber Roller - for all Rollers	2F-2	242053 Under floor Lashing Ring	1F-4
240013	Axle Kit - for Twin Roller	2F-2	242056 Tysafe Buckle for 50mm Webbing	1D-2
240014	Axle Kit - for Quad Roller	2F-2	242058 Pressed Rave Hook	1D-3
240015	Axle Kit - for Single Roller	2F-2	242061 Strap Winch	1F-1



242 continued		
242065	Twin-Fix Plate c/w Nylon Nuts - M6x16	1D-4
242066	Twin-Fix Plate c/w Nylon Nuts - M6x20	1D-4
242067	Twin-Fix Clamp Plate	1D-4
242068	Twin-Fix Sandwich Plate Assembly	1D-4
242074	Wanted Ring - Narrow	1D-4
242075	Wanted Ring - Wide	1D-4
243 Locks & Hinges		
243000	Hinge Set	1G-1
243001	Un-Bushed Door Gear Set	1G-3
243002	Plant-on Lock	1G-1
243003	Recessed Overcentre Lock	1G-1
243004	Flush Fit Panel Lock	1G-2
243005	Flush Fit Tee Handle Lock	1G-2
243006	Hinge Assembly	1G-2
245 Wire Ropes & Accessories		
245001	Replacement Thimble 6mm	3C-1
245002	Replacement Thimble 8mm	3C-1
245003	Wire Rope Grip 2x5mm	3C-1
245004	Wire Rope Grip 2x6mm	3C-1
245005	Wire Rope Grip 2x8mm	3C-1
245010	Steel Cable - 1.5mm x 1.83m	3C-1
245011	Steel Cable - 1.5mm x 500m	3C-1
245012	Steel Cable - 4mm x 30m	3C-1
245013	Steel Cable - 6mm x 15m	3C-1
245014	Steel Cable - 6mm x 30m	3C-1
245015	Steel Cable - 6mm x 100m	3C-1
245016	Steel Cable - 6mm x 2.33m with 1/8" BSE Swage End	3C-1
245017	Steel Cable - 8mm x 100m	3C-1
245018	Steel Cable - 6mm x 5m	3C-1
248 Plate Holders		
248001	UK Long Number Plate Holder	1E-1
248002	Commercial Square Number Plate Holder	1E-1
248003	UK Deep & Slimline Number Plate Holder	1E-2
248004	UK Square Number Plate Holder	1E-1
248008	Deep Number Plate Holder	1E-2